

*Combo Caddy  
Operator's Manual*

**125-836**





## INTRODUCTION

### **DUAL IMPLEMENT AND FERTILIZER CARRIER**

The Combo Caddy is yet another innovative Orthman implement engineered to provide the agricultural industry with unprecedented single field pass efficiency. The impressive lifting capacity of up to 40,000 lbs. allows the Combo Caddy to carry up to 1,000 gallons of liquid fertilizer in combination with two three point mounted implements. Effectively, the Combo Caddy minimizes weight applied to the towing device while combining multiple operations in a single implement to maximize single field pass efficiency.

Typically, the Combo Caddy is utilized to carry an Orthman **1tRIPr** preplant tillage tool in combination with a planter. This configuration combines preplant tillage and the planting application in a single implement.

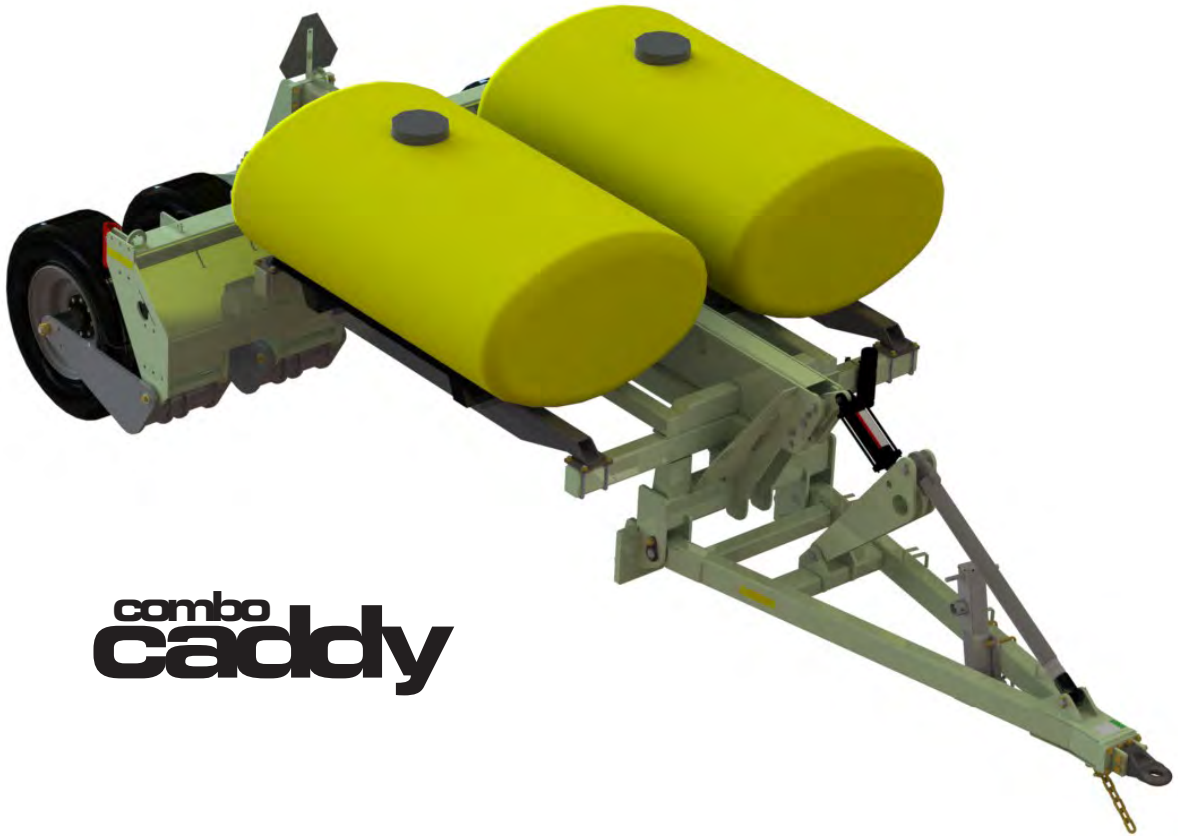

**combo  
caddy**

The Combo Caddy is available in four and six lift wheel configurations to carry a wide variety of implement sizes. A wide stance creates stability in the field as well as during transport. High lift clearance allows implement clearance in rough terrain. To increase lifting capacity, optional lift wheels (2) are available for addition to four lift wheel Caddies.

**INTRODUCTION****DUAL IMPLEMENT AND FERTILIZER CARRIER**

An optional fertilizer tank package can carry up to 1,000 gallons of liquid fertilizer to be incorporated by either carried implement. The fertilizer tank package relieves the towing device of the additional weight of saddle tanks, etc. An optional tire drive fertilizer pump mount package is available to divert liquid from fertilizer tanks to the intended incorporation tool.

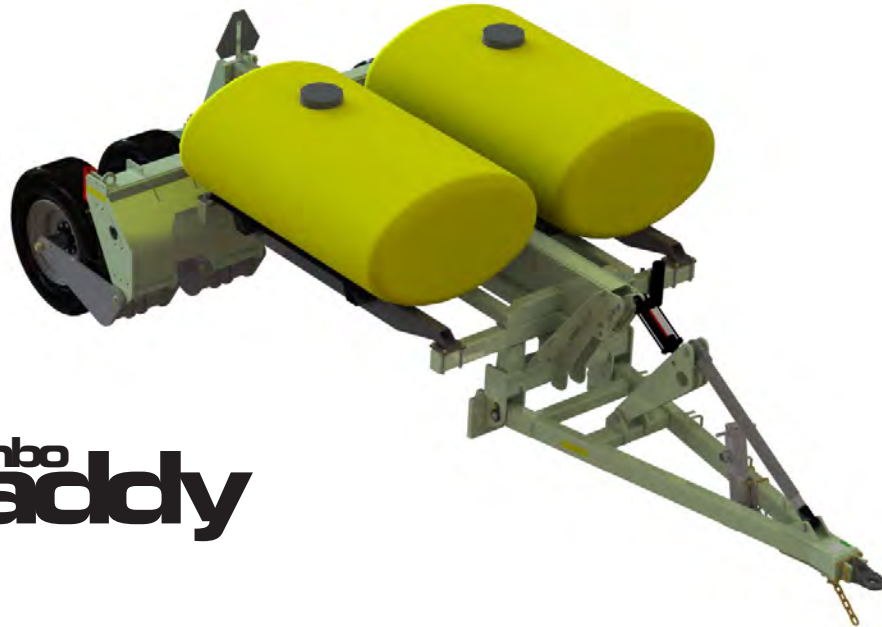
**combo  
caddy**

This manual is considered to be an integral component of the Combo Caddy and is designed to educate the owner and operators regarding safety, operation, maintenance, troubleshooting, and component identification. The owner and operators are responsible for reading and understanding the entire content of this manual. This manual is designed to keep the operator safe and knowledgeable as well as prolong the life of the implement, minimize downtime, and maximize profits. This manual should accompany the implement if it were ever to be sold.

This manual is sequentially designed and written. It is highly advisable to read the entire manual before manipulating the Combo Caddy in anyway. If the sequential process explained and illustrated in this manual is followed, all manipulations to the Combo Caddy will be simplified and easier for the personnel involved in the operation of the Combo Caddy.

We would like to thank you for placing your confidence in Orthman Mfg., Inc. Your Combo Caddy is manufactured to meet the highest standards and is built with precision and strength to increase your agricultural operation's dependability and profitability.

*Thank you for choosing Orthman*  
**STILL THE STRONGEST**



## **WARRANTY**

Orthman Mfg., Inc. warrants the whole goods products it manufactures to be free from defects in material or workmanship for a period of one (1) year from the date of sale of the product(s) to the original user. Products not manufactured, but supplied by Orthman Mfg., Inc. on Orthman products, are subject to, conform with, and are limited to the warranty of our suppliers.

Orthman Mfg., Inc. warrants the parts it manufactures to be free from defects in material or workmanship for a period of ninety (90) days from the date of delivery of the product(s) to the original user. Products not manufactured, but supplied by Orthman Mfg., Inc. on Orthman products, are subject to, conform with, and are limited to the warranty of our suppliers.

Warranty of Orthman whole goods and/or parts applies only to material and workmanship. Misuse, misapplication, neglect, alteration, accident, normal wear, or acts of God affecting Orthman products are not eligible for warranty.

Warranty of serial numbered goods will only be considered if the product has a completed Warranty Registration on file at Orthman. This Warranty Registration must be completed and returned to Orthman within thirty (30) days of the sale of the product(s) to the original user. *No serial numbered goods or related parts and/or labor will be warranted without a Warranty Registration on file.* Warranty issues falling within the first thirty days of a product's use will be handled at the discretion of Orthman. Warranty of parts will not require a Warranty Registration, but proof of date of delivery of the product to the original customer must be provided.

**WARRANTY CLAIMS:** A warranty claim and request to return defective product(s) must be presented to the Orthman Service Department by the selling dealer describing the defect in material or workmanship of an Orthman product(s) within ten (10) days of its discovery. This claim may be made via phone, e-mail, fax, or written request. Claims for warranty of serial numbered goods must include the Orthman product serial number and model number. Claims for warranty of parts will not require a product serial number or model number, but must be identified by an Orthman part number. Claims for warranty of whole goods or parts must also include proof of date of sale of the product to the original customer by an Orthman dealer.

The Orthman Service Department will proceed in making a preliminary decision as to the eligibility of the claim for warranty consideration. After the Orthman Service Department deems it necessary to proceed with warranty consideration, a Return Goods Authorization (RGA) will be completed by the Orthman Service Department in conjunction with the selling dealer. Upon completion of the RGA, the defective product(s) must be returned to Orthman to ensure warranty consideration. Defective product(s) must be returned to Orthman by either the selling dealer or the customer. Customer delivery of defective product(s) must be approved by Orthman and the selling dealer prior to delivery. The defective product(s) in question must be sent, freight prepaid, within sixty (60) days of the discovery of the product(s) failure and initial warranty claim. Replacement product(s) may be sent to the selling dealer, directly to the customer, or picked up at the Orthman facility. Replacement product(s), sent directly to the customer or picked up must be approved by Orthman and the selling dealer. At the discretion of the Orthman Service Department, replacement product(s) may be sent prior to, or after, the Orthman Service Department receives the defective product(s).

*Any variation in the above procedure is at the sole discretion of the Orthman Service Department.*

*No products will be accepted at Orthman without all proper paperwork completed including Warranty Registration and RGA(s).  
Parts returned to Orthman without proper authorization will be returned to the sender at the sender's expense.*

Orthman agrees to handle all warranty claims in a timely manner and will inform dealers of any revisions or modifications to the Orthman Warranty Policy. Eligible warranty claims will be processed by Orthman within sixty (60) days of receiving failed product(s) or a valid service or repair labor claim. Eligible warranty claims regarding returned product(s) or service and/or repair labor will be paid through a credit memo issued to the appropriate dealer's account as determined by the Orthman Service Department.

If a warranty claim is found to be ineligible for warranty coverage, the Orthman Service Department will be responsible to inform the dealer in order to determine the course of action to be taken. Orthman reserves the right to make changes in specification and design without notice and without incurring any obligations to owners of products previously sold.



© Copyright 2011  
Orthman  
Manufacturing Inc.  
Lexington, Nebraska

**All rights reserved.**

Orthman provides this manual without warranty of any kind, expressed or implied. This manual reflects the product at the time of publication. All information within is based upon current information on the publication date. Orthman assumes no responsibility for damages incurred due to the use of the illustrations, information, and specifications within this publication.

# Farm Safety

Contrary to the popular image of fresh air and peaceful surroundings, a farm is not a hazard-free work setting. Every year, thousands of farm workers are injured and hundreds more die in farming accidents. According to the National Safety Council, agriculture is the most hazardous industry in the nation.

## How You Can Improve Farm Safety

You can start by increasing your awareness of farming hazards and making a conscious effort to prepare for emergency situations including fires, vehicle accidents, electrical shocks from equipment and wires, and chemical exposures. Be especially alert to hazards that may affect children and the elderly. Minimize hazards by carefully selecting the products you buy to ensure that you provide good tools and equipment. Always use seat belts when operating tractors, and establish and maintain good housekeeping practices. Here are some other steps you can take to reduce illnesses and injuries on the farm:

- Read and follow instructions in equipment operator's manuals and on product labels.
- Inspect equipment routinely for problems that may cause accidents.
- Discuss safety hazards and emergency procedures with your workers.
- Install approved rollover protective structures, protective enclosures, or protective frames on tractors.
- Make sure that guards on farm equipment are replaced after maintenance.
- Review and follow instructions in material safety data sheets (MSDSs) and on labels that come with chemical products and communicate information on these hazards to your workers.

## Health and Safety Hazards on Farms

Farm workers including farm families and migrant workers are exposed to hazards such as the following:

| Danger                      | Potential Effect or Injury   | Prevention  |
|-----------------------------|--|---|
| Chemicals/Pesticides        | Skin and respiratory injury or death   | MSDS and proper Personal Protective Equipment. Review Manufacturers data sheets   |
| Cold                        | Illness, Frostbite or death  | Dress properly for the day.   |
| Dust                        | Respiratory injury or explosive combinations   | Be aware of your surroundings and activity  |
| Electricity                 | Shock, burns, fire, death  | Use a qualified professional for wiring dangerous electrical devices. Never overload a circuit. Replace damaged electrical devices or cords. Electrical tape will not insulate you from injury.                             |
| Grain bins, Silos           | Entrapment, Suffocation, Explosion from formation of dangerous gases and poisoning.                    | Make sure the bin is properly ventilated and maintained. Never walk the grain.  |
| Hand tools                  | Injury including cuts abrasions, electrocution, strains, sprains and death                             | Make sure you hand tools are in good condition. Never leave a damaged tooling accessible for someone else to use.   |
| Highway traffic             | Collisions resulting in injury or death  | Follow regulations, stay alert. Avoid alcohol and use of communication devices while driving  |
| Lifting and lifting devices | Back injury, sprains, strains. Falling material resulting in being struck or crushed by heavy material | Use proper lifting technique. Get help when the load is too heavy. Inspect chains, straps or cables routinely to make sure they are in good condition.  |
| Livestock handling          | Serious injury or death resulting from being pinned struck or trampled.                                | Always make sure you have adequate room and an escape route   |
| Machinery/Equipment         | Cuts, abrasions, amputations, death.   | Thoroughly read and understand your Owners Equipment Manual. Never operate the equipment without guards in place. Make sure the equipment can not be energized or otherwise put into operation while you are working on it. |
| Manure pits                 | Explosion from formation of dangerous gases. Suffocation. Poisoning                                    | Proper maintenance.   |
| Mud                         | Sprains, strains, entrapment and suffocation. Eye injury and skin irritation.                          | Proper Personal Protective Equipment. In some conditions a "Spotter" may be needed.   |
| Noise                       | Hearing damage   | Personal Protective Equipment.  |
| Ponds                       | Drowning   | Wear a life preserver and make sure help is readily available.  |
| Slips/Trips/Falls           | Sprains, strains, back and neck injury, bone breaks or death   | Keep work area free from clutter and organized. If working on anything elevated make sure you have appropriate guarding and/or fall protection such as a harness and lanyard.   |
| Sun/Heat                    | Sun burn, Heat Stroke, shock, death  | Use common sense on excessively hot days, use sun screen, wear a hat and stay hydrated.   |
| Toxic gases                 | Skin and respiratory injury or death. Explosion.   | MSDS and proper Personal Protective Equipment. Review Manufacturers data sheets   |
| Tractors                    | Cuts, abrasions, amputations, death.   | Thoroughly read and understand your Owners Equipment Manual. Never operate the equipment without guards in place. Anti-roll over devices.   |
| Wells                       | Electrocution, amputation, death   | Avoid contact with water while working on an electrical device. Always be sure the equipment can/will not be energized during repair or maintenance. Make sure all guarding is in place.                                    |
| Severe Weather              | Electrocution, "struck by" injuries, death   | Move to a safe place. Lightning, hail and tornadoes are unpredictable.  |

**Orthman Manufacturing, Inc. does not limit the potential effects or injuries nor prevention measures to those listed above. They are provided solely as a guideline to making your farm life safer. Always consult your Owner/Operators Manual for specific tool and equipment safety requirements.**

## High Risk Factors on Farms

The following factors may increase risk of injury or illness for farm workers:

- **Age** – Injury rates are highest among children age 15 and under and adults over 65.
- **Equipment and Machinery** – Most farm accidents and fatalities involve machinery. Proper machine guarding and doing equipment maintenance according to manufacturers' recommendations can help prevent accidents.
- **Protective Equipment** – Using protective equipment, such as seat belts on tractors, and personal protective equipment (such as safety gloves, coveralls, boots, hats, aprons, goggles, face shields) could significantly reduce farming injuries.
- Take precautions to prevent entrapment and suffocation caused by unstable surfaces of grain storage bins, silos, or hoppers. Never "walk the grain."
- Be aware that methane gas, carbon dioxide, ammonia, and hydrogen sulfide can form in unventilated grain silos and manure pits and can suffocate or poison workers or explode.
- Take advantage of safety equipment, such as bypass starter covers, power take-off master shields, and slow-moving vehicle emblems.
- **Medical Care** – Hospitals and emergency medical care are typically not readily accessible in rural areas near farms.

## The Benefits of Improved Safety and Health Practices

Orthman Manufacturing Provides this document in the hope that everyone that has a job to do, does it SAFELY. Our goal and yours should be to end each day in the best possible health. Better safety and health practices reduce fatalities, injuries, and illnesses as well as associated costs such as workers' compensation insurance premiums, lost production, and medical expenses. A safer and more healthful workplace improves morale and productivity.

**INTRODUCTION****TABLE OF CONTENTS**

|   |    |
|---|----|
| <b>Introduction</b>                                       |    |
| General Information - Combo Caddy                         | 1  |
| Warranty  | 3  |
| Farm Safety   | 4  |
| Table of Contents   | 6  |
| <br>  |    |
| <b>Important Safety Information</b>                       |    |
| Safety Alert Symbol - Signal Words - Shutdown and Storage | 8  |
| Your Protection - Safety Guidelines                       | 9  |
| Safe Transport - Warning and Safety Lights                | 10 |
| Safe Operation - No Riders                                | 11 |
| Practice Safe Maintenance                                 | 12 |
| Prepare for Emergencies                                   | 13 |
| Liquid Fertilizer - Safety Never Hurts                    | 14 |
| Safety Decals   | 15 |
| Orthman Decals  | 20 |
| <br>  |    |
| <b>Component Identification</b>                           |    |
| Terminology and Definitions                               | 22 |
| Component Identification                                  | 23 |
| <br>  |    |
| <b>Preparation and Setup</b>                              |    |
| Dual Fertilizer Tanks                                     | 27 |
| Dual Fertilizer Tanks - Installation                      | 28 |
| Tire Drive Fertilizer Pump Mount                          | 29 |
| Tire Drive Fertilizer Pump Mount - Installation           | 30 |
| Lift Wheel Package  | 39 |
| Lift Wheel Package - Installation                         | 40 |
| Lift Wheel Package Hydraulic Components - Installation    | 41 |
| Caddy to Primary Implement Connection                     | 42 |
| Caddy to Tractor Connection                               | 49 |
| Lift Wheel Scrapers                                       | 50 |

**INTRODUCTION****TABLE OF CONTENTS**

|  |           |
|--|-----------|
| <b>Preparation and Setup - cont.</b>               |           |
| Caddy to Secondary Implement Connection            | <b>51</b> |
| Simple Hydraulic Schematic                         | <b>53</b> |
| <b>Field Settings</b>                              |           |
| Caddy Height                                       | <b>54</b> |
| <b>Troubleshooting</b>                             |           |
| Installing Dual Fertilizer Tanks                   |           |
| Installing Tire Drive Fertilizer Pump Mount        |           |
| Installing Lift Wheel Package                      | <b>55</b> |
| Installing Lift Wheel Package Hydraulic Components |           |
| Primary Implement Connection                       |           |
| Caddy to Tractor Connection                        | <b>56</b> |
| Installing Lift Wheel Scrapers                     |           |
| Secondary Implement Connection                     |           |
| Simplified Hydraulic Schematic                     | <b>57</b> |
| <b>Maintenance</b>                                 |           |
| Practice Safe Maintenance                          | <b>58</b> |
| Lubrication  | <b>59</b> |
| Implement Inspection                               | <b>63</b> |
| Torque Specifications                              | <b>64</b> |
| Implement Storage                                  | <b>65</b> |





**IMPORTANT SAFETY INFORMATION**

**! IMPORTANT SAFETY INFORMATION !**

**SAFETY ALERT SYMBOL**



The **SAFETY ALERT SYMBOL** warns of potential hazards to personal safety and that extra precautions must be taken. When you see this symbol, carefully read the message(s) that follow. Follow all recommended precautions and safe operating practices in this manual.

*NOTE: Hazard control and accident prevention are dependent upon safety awareness and proper training of personnel involved in the operation of this implement.*

**! BE AWARE OF SIGNAL WORDS**

**SIGNAL WORDS** designate a degree or level of **HAZARD** seriousness. These **SIGNAL WORDS** include:



RED

**DANGER** indicates a hazardous situation that, if not avoided, will result in death or serious injury. **DANGER** is limited to extreme situations, typically for machine components which, for functional purposes, cannot be guarded.



ORANGE

**WARNING** indicates a potentially hazardous situation that, if not avoided, could result in death or serious injury. **WARNING** includes hazards that are exposed when safety guards are removed. **WARNING** may also be used to alert against unsafe practices.



YELLOW

**CAUTION** indicates a potentially hazardous situation that, if not avoided, may result in minor or moderate injury. **CAUTION** may also be used to alert against unsafe practices.

**! SHUTDOWN AND STORAGE**



**AVOID CRUSHING.** Make sure all personnel are clear of the implement. Lower implement to the ground, place tractor in park, turn off engine, and remove key.



**SUPPORT THE IMPLEMENT.** Use Caddy jack stand to support the implement. Store implement on a clean, dry, and level surface. An uneven surface could cause implement to shift or fall, resulting in injury or death, as well as implement damage. Securely support all implement components that must be raised. Store implement away from human activity.



## IMPORTANT SAFETY INFORMATION

**CAUTION**

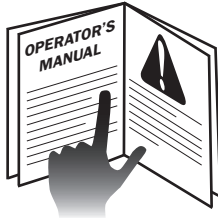

### **⚠ FOR YOUR PROTECTION**

**READ AND UNDERSTAND THE ENTIRE CONTENT OF THIS MANUAL BEFORE OPERATING OR SERVICING IMPLEMENT.** Read and understand all operator manuals for machinery used in conjunction with the Caddy.

Carefully **READ ALL SAFETY DECALS** in this manual as well as on the implement. Keep implement clean so decals are easily visible. Keep all safety decals in good, clean, and legible condition. Immediately replace damaged and/or missing decals. Replacement decals are available from your Orthman dealer.

Learn to operate the implement and all components properly. Do not let others operate implement without proper instruction. Unauthorized implement modifications may impair function and safety. If you do not understand any content in this manual or need assistance, contact your Orthman dealer.

*(Orthman Manufacturing Inc. - 75765 Rd. 435 - Lexington, NE 68850 - (308) 324-4654)*

### **⚠ EQUIPMENT SAFETY GUIDELINES**

Operator safety is the primary concern when designing an Orthman implement. Orthman integrates as many safety features into the implement as possible. You can avoid many hazards and possible accidents by observing precautions in this safety section.

Insist that yourself and personnel working with and around you follow all safety precautions. Be cautious when working with or around implement to avoid injury.



## IMPORTANT SAFETY INFORMATION

### **SAFE TRANSPORT**

- Engage transport locking devices and Caddy cylinder locks prior to transport.
- Plan your route to avoid traffic. Yield to traffic in all situations.
- Maximum transport speed is 20 mph (32 kph). Various conditions will require reduced speeds. Travel at speeds that allow for adequate control of stopping and steering.
- **AVOID ELECTROCUTION.** Be aware of overhead power lines. Contact or close proximity to power lines can result in injury or death. Use extreme care when operating implement near power lines.
- Know implement transport height and gross weight. Avoid overhead obstructions not allowing your transport height. Do not use bridges rated below implement gross weight.
- Make sure a slow moving vehicle (SMV) placard is mounted to the implement and is visible to other motorists.
- Make allowances for implement size when transporting. Sudden braking can cause a towed load to swerve and/or rollover. Never use independent braking with implement in tow as loss of control and/or rollover can result. Reduce speed if towed implement is not equipped with brakes.
- Do not coast. Always keep tractor or towing device in gear to provide engine braking when traveling downhill.
- Comply with state and local laws governing implement transport.



### **WARNING AND SAFETY LIGHTS**

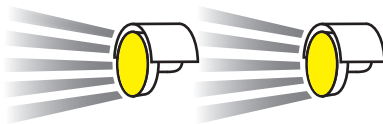

- Oversized implements and slow moving vehicles create a hazard when being transported on public roads.
- Make sure all warning, safety lights, and turning signals are working and clean. Use safety lighting when using public roads day and night. Replace missing or damaged lights immediately. Comply with state and local laws governing implement safety lighting.



## IMPORTANT SAFETY INFORMATION

### **SAFE OPERATION**

#### **CAUTION**

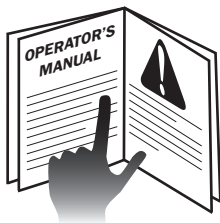

- **READ AND UNDERSTAND THE ENTIRE CONTENT OF THIS MANUAL BEFORE OPERATING OR SERVICING IMPLEMENT.** Implement is to be operated by qualified personnel only. Never let children operate implement. A complete understanding of safety precautions, operation, and maintenance is mandatory before implement use.

#### **DANGER**



- **AVOID ELECTROCUTION.** Be aware of overhead power lines. Contact or close proximity to power lines can result in injury or death. Use extreme care when operating implement near power lines.

#### **DANGER**



- Know implement transport height and gross weight. Avoid overhead obstructions not allowing your transport height. Do not use bridges rated below your gross weight.

- **AVOID ROLLOVER.** Do not fold or unfold implement and avoid sharp turns when on a hillside, as shift of weight could cause rollover. Operate implement at a safe distance from terrain irregularities and other obstructions that could cause rollover.

#### **WARNING**



- **AVOID CRUSHING.** Make sure all personnel are clear of implement at all times implement is in motion. Be aware of obstructions above, below, and around implement when in operation or transport. Injury or death can result from being struck by the implement.

### **NO RIDERS**

#### **WARNING**



- **NEVER ALLOW RIDERS ON TRACTOR OR IMPLEMENT.** Riders hinder operator visibility and can be thrown from the implement and/or be struck by foreign objects resulting in injury or death.



## IMPORTANT SAFETY INFORMATION

### **PRACTICE SAFE MAINTENANCE**

- Proper maintenance is your responsibility. Maintenance neglect and/or poor maintenance practices can result in injury or death. Always use the proper tools to maintain implement.



- **AVOID CRUSHING.** Make sure all personnel are clear of the implement. Lower implement to the ground, place tractor in park, turn off engine, and remove key.



- **SUPPORT THE IMPLEMENT.** Use three point Caddy hitch bar stands or drawbar Caddy jack stand to support the implement. Park implement on a clean, dry, and level surface. An uneven surface could cause implement to shift or fall, resulting in injury or death, as well as implement damage. Securely support all implement components that must be raised. Remove buildup of grease, oil, or debris prior to maintaining implement.



- **AVOID ENTANGLEMENT.** Never lubricate or service implement in motion. Keep away from power driven parts when in motion. Disengage power sources prior to maintaining implement. Injury or death can result from contact with power driven parts when in motion.



- **AVOID CRUSHING.** Do not stand between the tractor and implement when connecting or disconnecting implement. Injury or death can result from being trapped between the tractor and implement.



- Escaping pressurized hydraulic fluid can penetrate skin, resulting in injury or death. Relieve hydraulic system pressure before connecting or disconnecting tractor. Use cardboard or wood, **NOT BODY PARTS**, to check for suspected hydraulic leaks. Wear protective gloves and safety glasses or goggles when working with hydraulic systems. If an accident occurs, see a doctor immediately for proper treatment.



## IMPORTANT SAFETY INFORMATION

### **PRACTICE SAFE MAINTENANCE**



- Never operate a combustion engine in an enclosed area. Make sure there is adequate ventilation. Exhaust fumes can cause asphyxiation.



- Be extremely careful working around unshielded sharp edges. Injury may result from contact with sharp edges.
- Keep all parts in good condition and properly installed. Replace damaged or missing parts immediately.
- Remove tools and unused parts prior to implement operation.

### **PREPARE FOR EMERGENCIES**



- Be prepared for a fire. Keep a readily accessible fire extinguisher at all times.
- Keep a readily accessible stocked first aid kit and emergency phone numbers for your doctor, hospital, ambulance, and fire department.
- Wear protective clothing and equipment. Wear clothing appropriate for the situation. Protect your eyes, ears, hands, and feet with the use of protective goggles, ear plugs, gloves, boots, etc.



## IMPORTANT SAFETY INFORMATION

### **LIQUID FERTILIZER**

The Combo Caddy can be accessorized with an optional dual liquid fertilizer tank package to apply liquid fertilizer.



• **LIQUID FERTILIZER APPEARS HARMLESS. DIRECT EXPOSURE TO LIQUID FERTILIZER IS EXTREMELY DANGEROUS AND CAN RESULT IN INJURY AND/OR DEATH.**

- Keep a clean supply of water readily accessible in case of exposure to liquid fertilizer.
- Wear protective goggles and gloves when working around liquid fertilizer. Be sure all persons involved in the operation are properly trained concerning the dangers and precautions involved in the application of liquid fertilizer.
- If you choose to apply liquid fertilizer, it is advisable to consult documented information regarding safe handling and application of liquid fertilizer. Information is available from the following recognized sources:
  1. American National Standards Institute - ANSI - [www.ansi.org](http://www.ansi.org) - (212) 642-4900
  2. Material Safety Data Sheets - MSDS - [www.msdsonline.com](http://www.msdsonline.com)
  3. National Safety Council - [www.nsc.org/necas](http://www.nsc.org/necas)
  4. The Fertilizer Institute - [www.tfi.org](http://www.tfi.org)
  5. United States Department of Transportation - D.O.T. - [www.dot.gov](http://www.dot.gov)
  6. Compressed Gas Association - [www.cganet.com](http://www.cganet.com)

### **SAFETY NEVER HURTS**

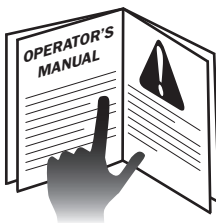

**READ AND UNDERSTAND THE ENTIRE CONTENT OF THIS MANUAL BEFORE OPERATING OR SERVICING IMPLEMENT.**

- Understand all implement functions.
- Never stand between tractor and implement when connecting or disconnecting implement.
- Be aware of all surroundings before moving implement.
- Operate implement from operator's seat only.
- Never mount or dismount a moving tractor.
- Never leave engine running when implement is unattended.
- Keep away from power driven parts when in motion.
- Make sure all personnel are clear before lowering implement to the ground.



**IMPORTANT SAFETY INFORMATION**

**SAFETY DECALS**

**DANGER**

**WARNING**

**CAUTION**

Safety decals promote awareness and knowledge concerning safe operation and maintenance of the implement.

Carefully **READ ALL SAFETY DECALS** in this manual as well as on the implement. Keep implement clean so decals are easily visible. Keep all decals in good and legible condition. Immediately replace damaged and/or missing decals. Replacement decals are available from your Orthman dealer.

**NOTE:** To install decals: Thoroughly clean area where decal is to be placed and attach decal void of bubbles. Refer to this safety information section for proper decal placement.

**NOTE:** Decal placement for both drawbar and three point Caddies are illustrated below. Common (drawbar and three point) Caddy decals with common locations are illustrated once.

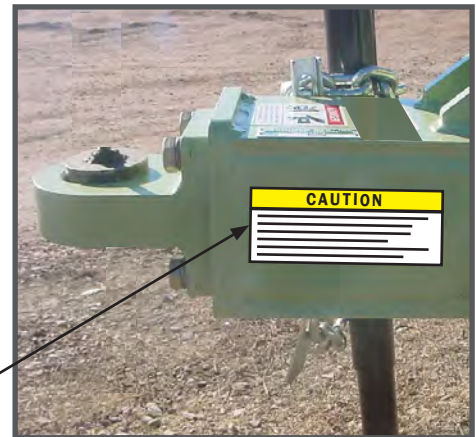

(left side Caddy hitch)

|   |
|---|
|  <p><b>CAUTION</b></p>   |
| <ol style="list-style-type: none"> <li>1. Read and understand all operator manuals before implement use.</li> <li>2. Follow all tractor or towing device operating procedures and safety guidelines.</li> <li>3. Do not allow riders on implement.</li> <li>4. Lower implement to the ground, place tractor in park, turn off engine, and remove key.<br/>Wait for all moving parts to come to a complete stop before working on implement.</li> <li>5. Be extremely careful working around unshielded sharp edges.</li> <li>6. Make sure all safety lighting and decals are clean. Use hazard lights when in transport.</li> <li>7. Engage all safety devices before transporting or working beneath implement.</li> <li>8. Contact or close proximity to power lines can result in electrocution.</li> <li>9. Review all safety instructions with all operators on a frequent basis.</li> </ol> <p style="text-align: right; font-size: small;">153-044</p> |

**153-044**





## IMPORTANT SAFETY INFORMATION

### SAFETY DECALS

Safety decals promote awareness and knowledge concerning safe operation and maintenance of the implement. Immediately replace damaged and/or missing decals. Replacement decals are available from your Orthman dealer.



153-167



(upper side Caddy hitch)



**IMPORTANT SAFETY INFORMATION**

**SAFETY DECALS**

Safety decals promote awareness and knowledge concerning safe operation and maintenance of the implement. Immediately replace damaged and/or missing decals. Replacement decals are available from your Orthman dealer.

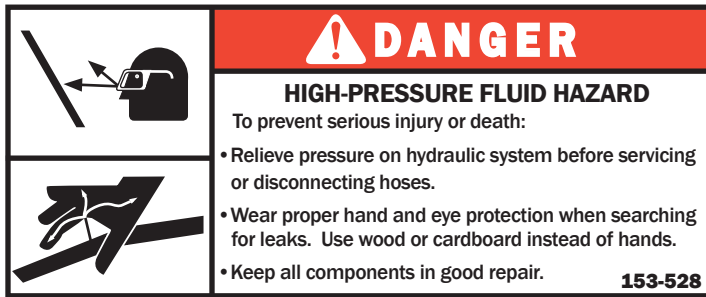

(left side Caddy hitch)

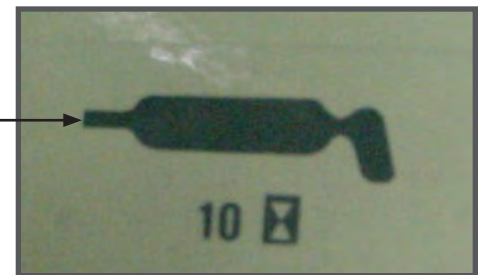

(refer to maintenance section)



**IMPORTANT SAFETY INFORMATION**

**SAFETY DECALS**

Safety decals promote awareness and knowledge concerning safe operation and maintenance of the implement. Immediately replace damaged and/or missing decals. Replacement decals are available from your Orthman dealer.

**! IMPORTANT**

Equipment operators should understand the enclosed manual before operating this equipment. Replacement manual, call 308-324-4654

Orthman Mfg., Inc. - 75765 Rd. 435 - Lexington, NE 68850  
153-101

(manual enclosure) **153-101**



(front left Caddy)

**! CAUTION**

1. Read and understand all operator manuals before implement use.
2. Follow all tractor or towing device operating procedures and safety guidelines.
3. Do not allow riders on implement.
4. Lower implement to the ground, place tractor in park, turn off engine, and remove key. Wait for all moving parts to come to a complete stop before working on implement.
5. Be extremely careful working around unshielded sharp edges.
6. Make sure all safety lighting and decals are clean. Use hazard lights when in transport.
7. Engage all safety devices before transporting or working beneath implement.
8. Contact or close proximity to power lines can result in electrocution.
9. Review all safety instructions with all operators on a frequent basis.

153-044

**153-044**



(rear center Caddy)

**! DANGER**

Keep all persons and objects clear while any part of this machine is in motion. Serious injury or death can result from being pinched.

153-167

**153-167**



## IMPORTANT SAFETY INFORMATION

### SAFETY DECALS

Safety decals promote awareness and knowledge concerning safe operation and maintenance of the implement. Immediately replace damaged and/or missing decals. Replacement decals are available from your Orthman dealer.

(ASAE Standard Reflective)

- 153-172**  
YELLOW
- 153-171**  
ORANGE
- 153-173**  
RED



(rear left Caddy)

- 153-172**  
YELLOW
- 153-171**  
ORANGE
- 153-173**  
RED



(rear right Caddy)

- 153-173**  
RED

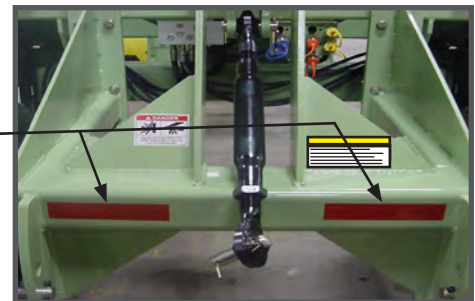

(rear center Caddy)



**IMPORTANT SAFETY INFORMATION**

**SAFETY DECALS**

**153-172**

**YELLOW**

(1 per right and left side of Caddy hitch frame)

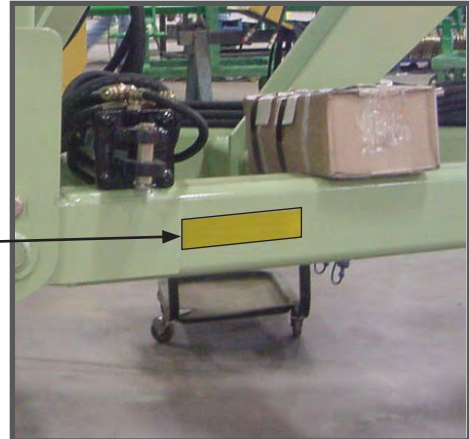

(right Caddy hitch frame)

**ORTHMAN DECALS**



**153-206**



(front right Caddy)



**153-207**



(front left Caddy)



**IMPORTANT SAFETY INFORMATION**

**ORTHMAN DECALS**



153-208



153-209



(rear center Caddy)



153-011



(upper side drawbar Caddy hitch)



(upper side three point Caddy hitch)

**COMPONENT IDENTIFICATION****COMPONENT IDENTIFICATION****TERMINOLOGY AND DEFINITIONS**

**CADDY** - When Caddy is referenced, information will pertain regardless of hitch style or optional attachments.

**TRACTOR** - Any towing device used to pull the Caddy, regardless of hitch style.

**DRAWBAR CADDY** - A Caddy equipped with a drawbar style hitch to tractor connection.

**RIGHT AND LEFT** - Right and left is determined by facing in the same direction the implement will travel while in use.

**FRONT AND REAR** - Front and rear is determined by standing to one side of the implement. (*front - toward the tractor, rear - away from the tractor*)

**PRIMARY THREE POINT HITCH** - The three point hitch located toward the mid-section of the Caddy. (*carries the primary implement; i.e., 1tRIPr*)

**SECONDARY THREE POINT HITCH** - The three point hitch located to the rear of the Caddy. (*carries the secondary implement; i.e., planter*)

The Caddy is engineered to essentially carry two three point implements. (*A typical configuration would entail a 1tRIPr carried by the primary three point hitch then followed by a planter carried by the secondary three point hitch.*)

**PRIMARY IMPLEMENT** - The primary implement (*i.e., 1tRIPr*) is carried by the primary three point hitch.

**SECONDARY IMPLEMENT** - The secondary implement (*i.e., planter*) is carried by the secondary three point hitch.

**INCORPORATION IMPLEMENT** - Either implement carried by the Caddy with capabilities of fertilizer application. The primary or secondary implement may serve as an incorporation implement.

**FERTILIZER** - Any liquid housed by dual tanks mounted to the Caddy.

**FRONT HYDRAULIC MANIFOLD** - Hydraulic manifold mounted to the left hand side of the Caddy frame. (*directly upward from the primary three point hitch*)

**REAR HYDRAULIC MANIFOLD** - Hydraulic manifold mounted to the rear and bottom of the Caddy frame. (*directly in front of the secondary three point hitch*)



## COMPONENT IDENTIFICATION

### COMPONENT IDENTIFICATION

The majority of the Caddy is assembled at Orthman Mfg., Inc. To ensure safe and efficient transport from the manufacturer, various optional attachments may need to be installed upon delivery.

- Installation of optional attachments available to complement the Combo Caddy are illustrated and explained in the preparation and setup section of this manual.

#### CAUTION

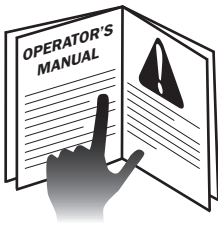

- If an Orthman toolbar is used in conjunction with the Caddy, be sure to read the toolbar operator's manual before attempting to operate the implement. Read and understand all operator manuals for machinery used in conjunction with the Caddy.

- Before each use, check hardware for wear and proper torque. (pg. 64) Replace damaged or missing hardware with hardware of identical grade to restore implement to original specifications.

This component identification section is designed to familiarize the operator with the major components of the Caddy prior to the installation of various optional attachments covered in the preparation and setup section.

### CADDY HITCH

Jack Stand Storage Harness

Hitch Frame

Jack Stand

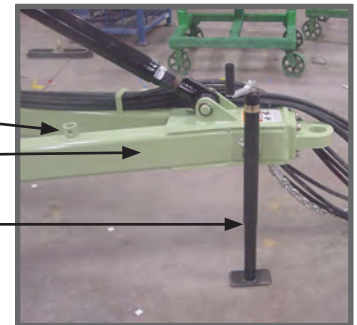

(front right Caddy)





**COMPONENT IDENTIFICATION**

**COMPONENT IDENTIFICATION**

**PRIMARY THREE POINT HITCH**  
(Caddy to primary implement connection)

Third Link

Primary Implement Hydraulic Connections  
(circled - green - used for 1tRIPr toolbar fold)

Lower Hitch Tugs

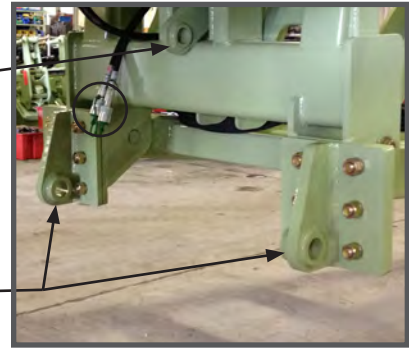

**FERTILIZER TANK MOUNT**  
(left tank mount pictured)

(refer to preparation and setup - pg. 27)

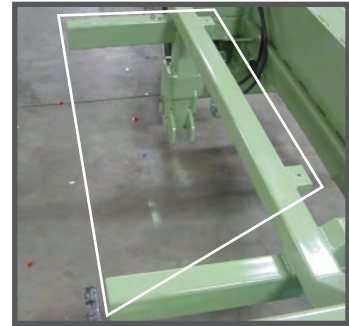

(left side Caddy)

**DUAL FERTILIZER TANKS**

Right Hand Fertilizer Tank

Left Hand Fertilizer Tank



(front center Caddy)



**COMPONENT IDENTIFICATION**

**COMPONENT IDENTIFICATION**

**SIDE PLATE**

(mounting platform for additional lift wheels)

Lift Wheel Mounting Bolt Holes (10) ⊗

(refer to preparation and setup - pg. 40)

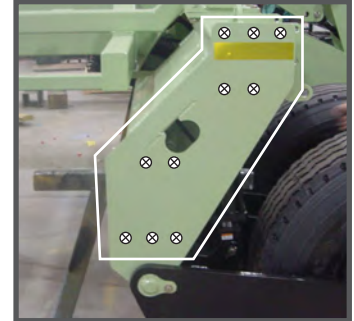

(left side Caddy)

**LIFT WHEELS**

(four lift wheels)

(shown in transport position, fully extended lift cylinders)



(rear left Caddy)

**LIFT WHEEL CYLINDER AND CYLINDER STOP PACKAGE**

Lift Wheel Cylinder

Cylinder Stop Package contains:

- 1. (1) 1 inch stop
- 2. (1) 1 1/2 inch stop
- 3. (1) 2 inch stop
- 4. (1) 4 1/4 inch stop

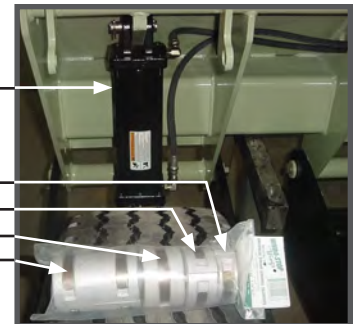

(rear left Caddy lift wheel)

**SECONDARY THREE POINT HITCH**

(Caddy to secondary implement connection)

Third Link

Lower Hitch Tugs

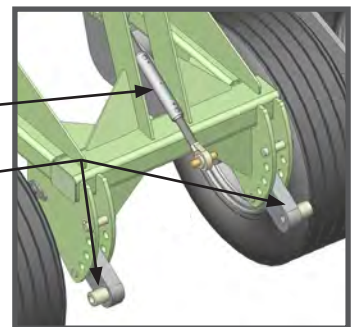

(rear center Caddy)



# COMPONENT IDENTIFICATION

## COMPONENT IDENTIFICATION

### HYDRAULIC CONNECTIONS

(Caddy to tractor connections circled)

- Red (Caddy lift wheels)
- Green (primary implement toolbar fold)
- Orange (auxillary)
- Yellow (planter markers)
- Blue (planter blower)
- Safety Chain —————
- (drawbar Caddy only)

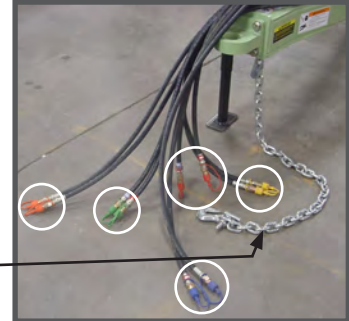

(front drawbar Caddy)

### PRIMARY IMPLEMENT HYDRAULIC CONNECTIONS

(Caddy to primary implement connection circled)

- Front Hydraulic Manifold —————
- Green (primary implement toolbar fold)
- (used for 1tRIPr toolbar fold)

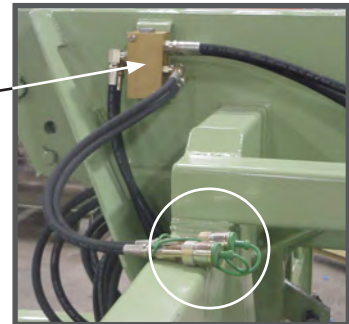

(left side Caddy)

### SECONDARY IMPLEMENT HYDRAULIC CONNECTIONS

(Caddy to secondary implement connections circled)

- Rear Hydraulic Manifold —————
- Green (secondary implement toolbar fold)
- Orange (auxillary)
- Yellow (planter markers)
- Blue (planter blower)

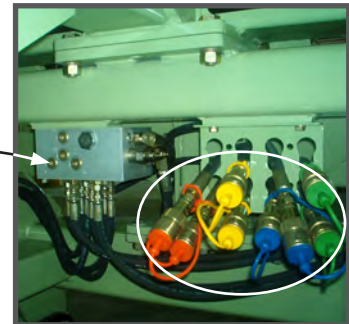

(rear center Caddy)

### CYLINDER LOCK

(when transporting Caddy, use cylinder lock in case of lift wheel hydraulic failure)

- Cylinder Lock —————
- (1 per right and left side of Caddy)
- (pictured in the storage position)



(rear right Caddy view)



**PREPARATION AND SETUP**

**PREPARATION AND SETUP**

**CAUTION**

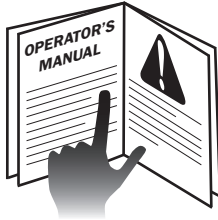

**⚠ CAREFULLY READ AND UNDERSTAND** each instructional sequence within this preparation and setup section before attempting to accomplish any task illustrated and explained in this section. It is imperative that the instructional processes are fully understood before proceeding. Various preparation and setup tasks require equipment and/or tools not common to all agricultural operations. It is highly advisable for all personnel involved in the operation to thoroughly read and understand the entire content of this manual before attempting to operate or work on the Combo Caddy.

The majority of the Combo Caddy is assembled at Orthman Mfg., Inc. To ensure safe and efficient transport from the manufacturer, various optional attachments may need to be installed upon delivery.

Follow this section in the order that it is printed. If you encounter a section that does not apply to your Caddy or the optional attachments you have purchased, proceed to the next section.

- Optional attachments available to complement the Combo Caddy are illustrated and explained in this preparation and setup section of this manual.

**DUAL FERTILIZER TANKS**

Optional dual fertilizer tanks can carry up to 1,000 gallons of liquid fertilizer to further increase single field pass efficiency. The dual fertilizer tanks relieve the towing device of additional saddle tank weight while increasing fertilizer carrying capacity. An optional tire drive fertilizer pump package is available to divert the fertilizer from the fertilizer tanks to the intended (primary or secondary implement) incorporation implement.



**NOTE:** Installation of optional dual fertilizer tanks will only apply to a Combo Caddy purchased less dual fertilizer tanks and tanks were purchased at a later date.



## PREPARATION AND SETUP

### INSTALLATION DUAL FERTILIZER TANKS



**• AVOID CRUSHING.** Lower implement to the ground, place tractor in park, turn off engine, and remove key. Park implement on a clean, dry, and level surface. An uneven surface could cause implement to shift or fall, resulting in personal injury or death, as well as implement damage.

**• SUPPORT THE IMPLEMENT.** Use three point Caddy hitch bar stands or drawbar Caddy jack stand to support the implement. Remove any buildup of grease, oil, or debris prior to installing dual fertilizer tank package.

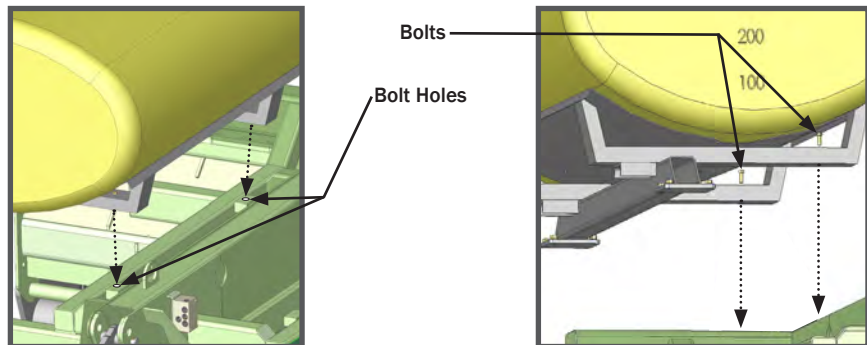
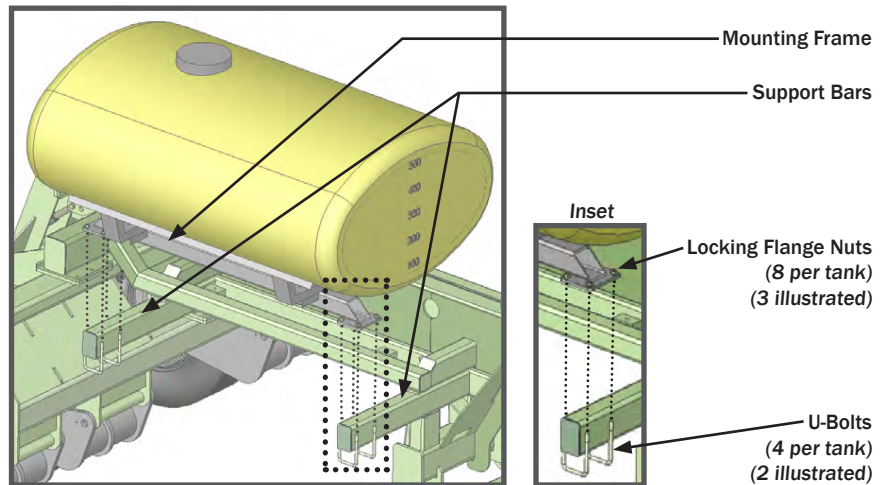

153-167

1. Suspend tank and mounting frame above Caddy frame.
2. Visually align mounting frame, support bars, bolts, and bolt holes.
3. **SLOWLY** lower tank and mount assembly while aligning bolt holes. Use a punch or alignment tool to position tank.
4. Insert bolts through tank mounting frame and bolt holes. Use lock washers and nuts (not pictured) to secure bolts.
6. Mount the mounting frame to the support bars with u-bolts and locking flange nuts.
7. Tighten all hardware to proper torque specifications. (pg. 64)



## PREPARATION AND SETUP

### TIRE DRIVE FERTILIZER PUMP MOUNT

An optional tire drive fertilizer pump mount made to fit the John Blue LM2455 Piston Pump is available to mount directly to the Caddy frame. The pump drive tire comes into contact with a Caddy lift wheel when in the field position to activate the pump and divert liquid fertilizer to the desired incorporation implement.

The pump mount can be mounted to the right or left hand side of the Caddy frame. The pump drive tire will be driven by either the far right hand or far left hand Caddy lift tire. For the purposes of the following installation instructions, the left hand side of the Caddy is illustrated. Regardless of desired pump mount location, the following instructions will pertain.

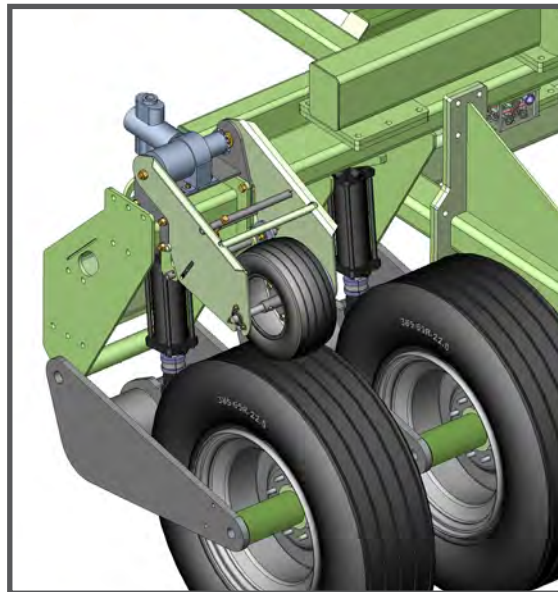

**NOTE:** The Orthman tire drive fertilizer pump mount package does not include a pump or pump drive sprocket. Both of these items are periodically illustrated in the above and following illustrations to better illustrate the installation process. Both of the pump and pump drive sprocket will need to be provided by the producer and will be notated as such.

Caddy pump drive tire: 48.5" circumference.  
 Caddy lift tire: 136.5" circumference.  
 Ground speed: operator preference.

The information provided above, in addition to pump specifications, will allow for the correct calculation of pump drive sprocket specifications needed to achieve desired fertilizer application rate. (contact your fertilizer provider)



**NOTE:** Installation of the tire drive fertilizer pump mount is simplified if the Caddy lift wheel cylinders are slightly extended to provide more working area. Refer to (pg. 57) Caddy to tractor hydraulic connections to lift the Caddy frame to provide more working area. Connecting the red (Caddy to tractor) hydraulic connections will allow the lift wheels to lift the Caddy frame and provide adequate working area. Use cylinder locks in case of hydraulic failure. (pg. 25)



## PREPARATION AND SETUP

### INSTALLATION TIRE DRIVE FERTILIZER PUMP MOUNT



**AVOID CRUSHING.** Lower implement to the ground, place tractor in park, turn off engine, and remove key. Park implement on a clean, dry, and level surface. An uneven surface could cause implement to shift or fall, resulting in personal injury or death, as well as implement damage.

**SUPPORT THE IMPLEMENT.** Caddy jack stand to support the implement. Use cylinder locks in case of hydraulic failure. (pg. 23). Remove any buildup of grease, oil, or debris prior to installing tire drive fertilizer pump mount.



153-167

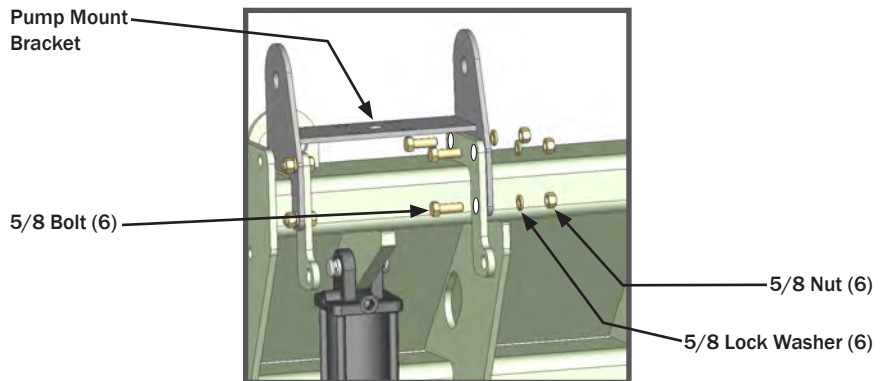
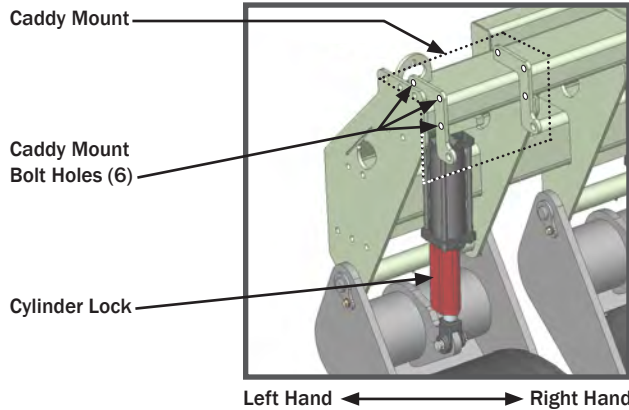

**NOTE:** All hardware sizes are notated due to the varying sizes and quantities included in the tire drive fertilizer pump mount package. Left hand bolts, lock washers, and nuts (3) are fully installed in the above illustration.



1. Place pump mount bracket on Caddy mount.
2. Align pump mount bracket and Caddy mount bolt holes.
3. Install (6) bolts, lock washers, and nuts.
4. Tighten all hardware to proper torque specifications. (pg. 64)



**PREPARATION AND SETUP**

**INSTALLATION  
TIRE DRIVE FERTILIZER PUMP MOUNT**

**NOTE:** The lift wheel cylinder is removed from the following illustrations to better illustrate the tire drive fertilizer pump mount installation sequence.

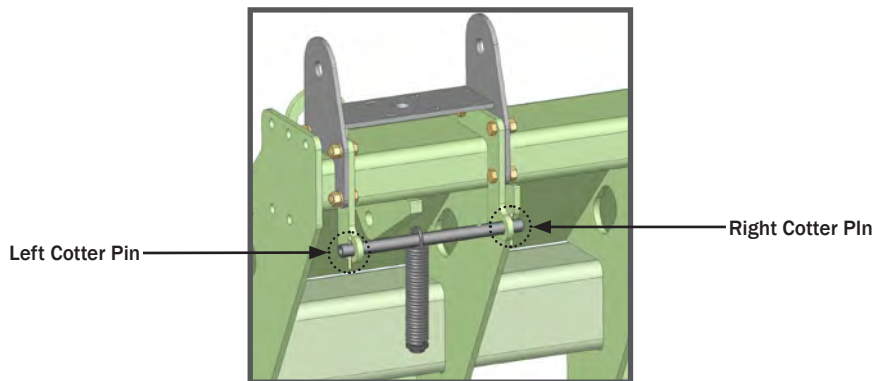
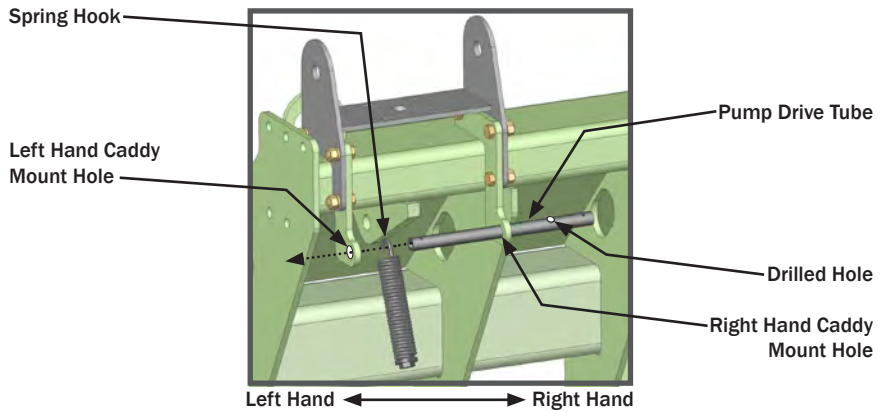

1. Thread pump drive tube (2 per package) through lowest right hand Caddy mount hole.
2. Thread pump drive tube through spring hook.
3. Thread pump drive through lowest left hand Caddy mount hole.

**NOTE:** Make sure the pump drive tube is installed (drilled hole in tube on right hand side) as pictured above.

4. Insert and spread cotter pins on left and right hand ends of the pump drive tube.
5. Let spring dangle as pictured.





## PREPARATION AND SETUP

### INSTALLATION TIRE DRIVE FERTILIZER PUMP MOUNT

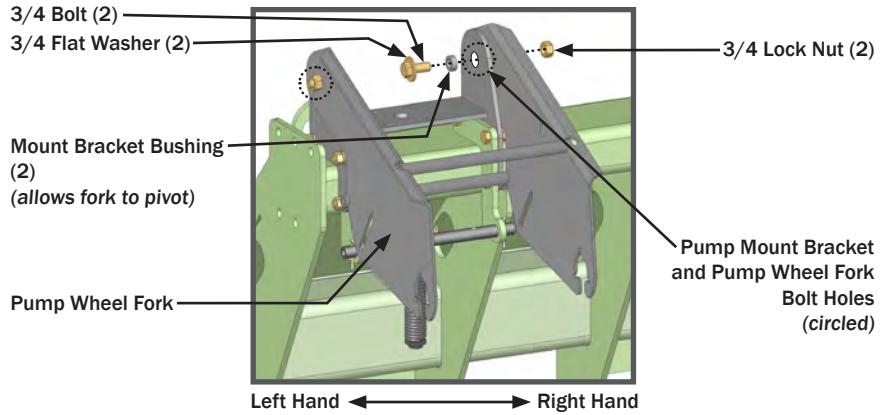

1. Align pump mount bracket and both pump wheel fork bolt holes.
2. Install (2) mount bracket bushings into both pump mount bracket and pump wheel fork bolt holes.
3. Use (2) bolts, flat washers, and lock nuts to secure pump wheel fork to pump mount bracket.
4. Do not overtighten. Pump wheel fork needs to pivot independent of the Caddy mount. Overtightening will not allow pump wheel fork to pivot vertically and maintain contact with the Caddy lift tire.

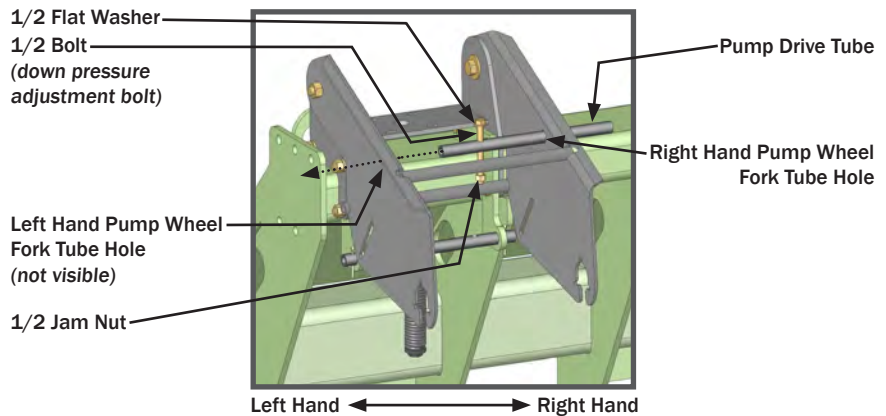

1. Thread pump drive tube through right hand pump wheel fork tube hole.
2. Place flat washer on bolt.
3. Insert bolt into drilled hole in pump drive tube.
4. Thread nut approximately halfway up onto bolt.



## PREPARATION AND SETUP

### INSTALLATION TIRE DRIVE FERTILIZER PUMP MOUNT

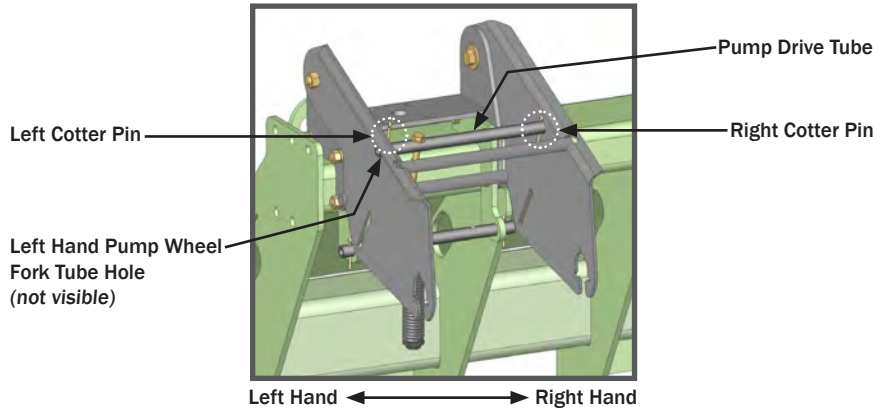

1. Insert pump drive tube through left hand pump wheel fork tube hole.
2. Insert and spread cotter pins on left and right ends of the pump drive tube. (cotter pins installed inside pump wheel fork frame)

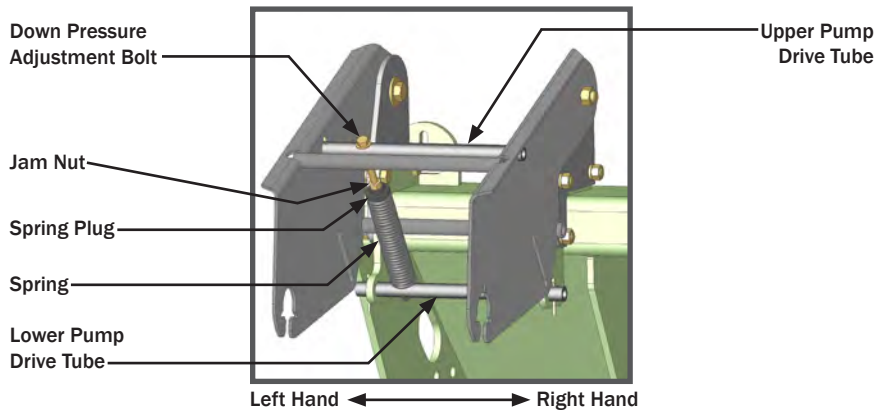

1. Make sure the jam nut is threaded approximately halfway up onto the down pressure adjustment bolt.
2. Rotate spring and spring plug upwards to align with the down pressure adjustment bolt.
3. Thread down pressure adjustment bolt into spring plug until spring hook is tight against lower pump drive tube.
4. Tighten jam nut against spring plug to torque specifications. (pg. 64)

**NOTE:** Down pressure adjustment may be necessary after initial field trial.

To adjust tire drive fertilizer pump mount down pressure:

1. Loosen jam nut from spring plug.
2. Adjust down pressure adjustment bolt. (clockwise - increase, counterclockwise - decrease)
3. Tighten jam nut against spring plug to torque specifications. (pg. 64)



**PREPARATION AND SETUP**

**INSTALLATION  
TIRE DRIVE FERTILIZER PUMP MOUNT**

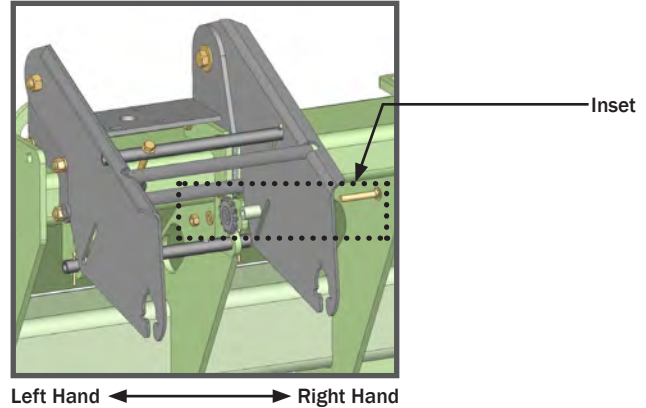

**IDLER SPROCKET ASSEMBLY**

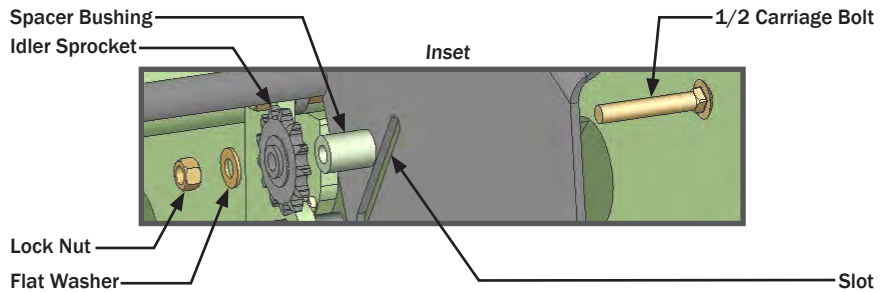

1. Insert carriage bolt through slot.
2. Thread carriage bolt through spacer bushing, idler sprocket, and flat washer.
3. Secure hardware with lock nut.
4. Tighten hardware to proper torque specifications. (pg. 64)

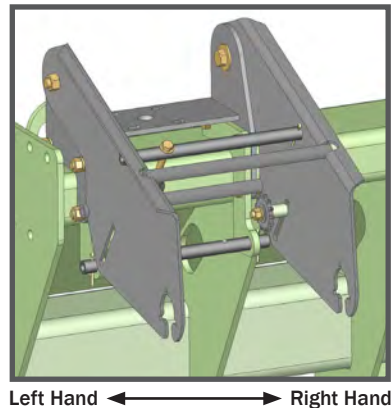



**PREPARATION AND SETUP**

**INSTALLATION  
TIRE DRIVE FERTILIZER PUMP MOUNT**

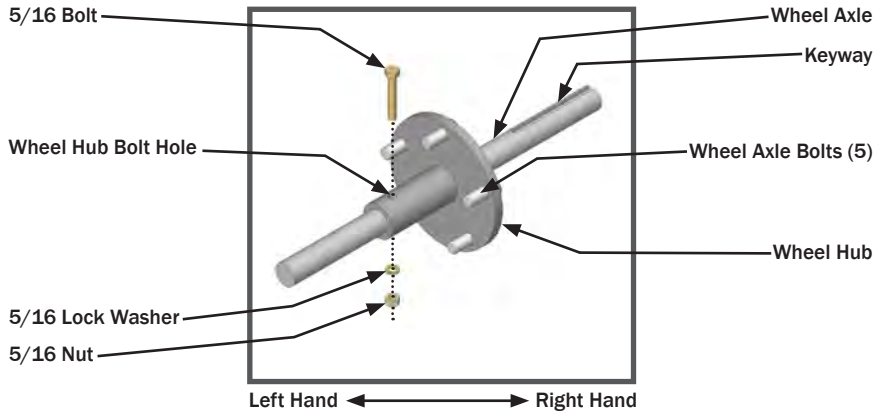

1. Align wheel hub bolt hole and wheel axle bolt hole.
2. Insert bolt through wheel hub bolt hole and wheel axle bolt hole.
3. Secure wheel hub to wheel axle with lock washer and nut.
4. Tighten all hardware to proper torque specifications. (pg. 64)

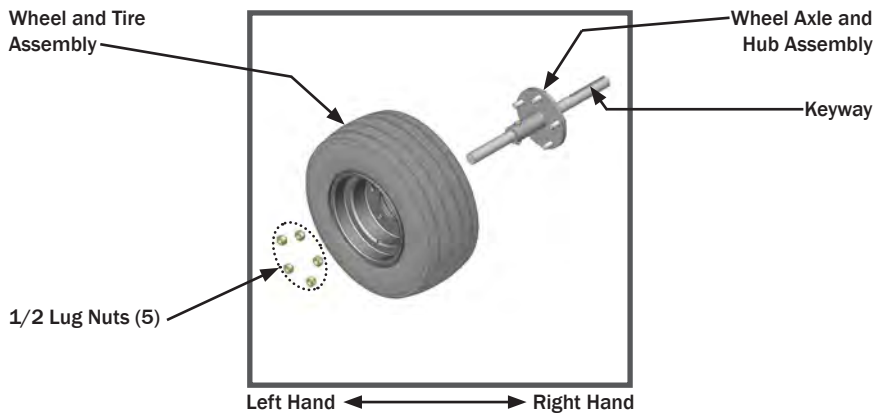

1. Insert wheel axle and hub assembly through wheel and tire assembly.
2. Secure wheel axle and hub assembly to wheel and tire assembly with lug nuts (5).
3. Tighten all hardware to proper torque specifications. (pg. 64)



## PREPARATION AND SETUP

### INSTALLATION TIRE DRIVE FERTILIZER PUMP MOUNT

**NOTE:** Caddy pump drive tire: 48.5" circumference. Caddy lift tire: 136.5" circumference. Ground speed: operator preference. This information, in addition to pump specifications, will allow for the correct calculation of pump drive sprocket specifications needed to achieve desired fertilizer rate. (contact your fertilizer provider)

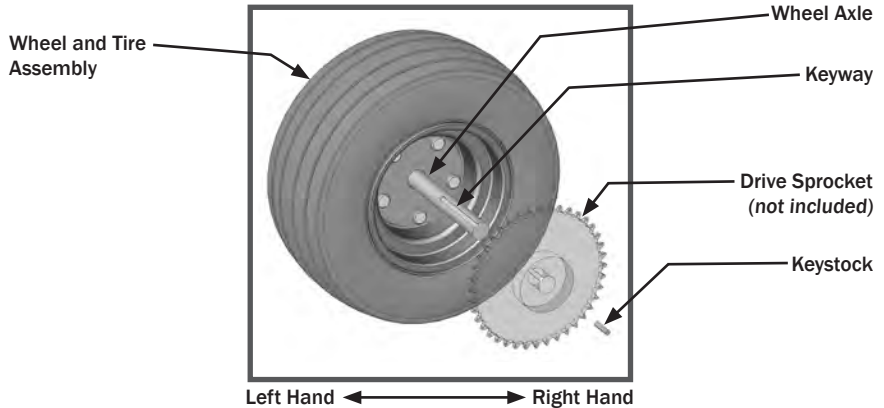

1. Slide your drive sprocket onto wheel axle.
2. Align wheel axle keyway and drive sprocket keyway.
3. Visually align drive sprocket with idler sprocket.
3. Insert keystock to secure drive sprocket to wheel axle.

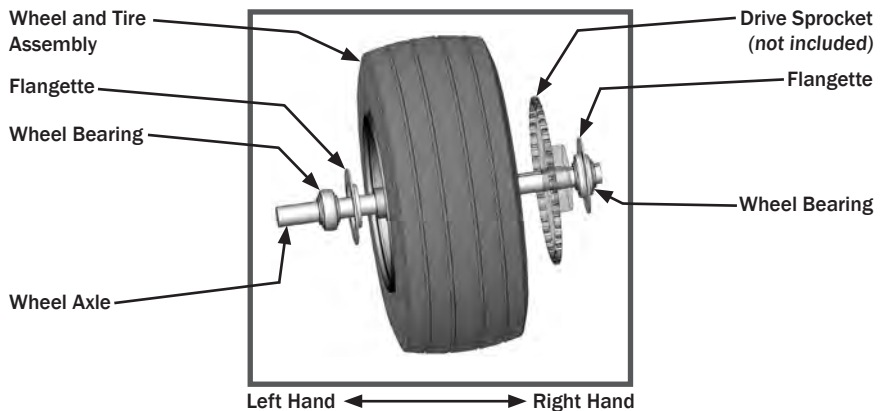

1. Place a flangette on the left and right hand sides of the wheel axle with the bevel towards the wheel.
2. Place a wheel bearing on the left and right hand sides of the wheel axle.

**NOTE:** Often flangettes will "snap" onto wheel bearings as pictured above on the right hand side of the assembly. Bearing carrier installation is simplified if flangettes "snap" onto wheel bearings.



**PREPARATION AND SETUP**

**INSTALLATION  
TIRE DRIVE FERTILIZER PUMP MOUNT**

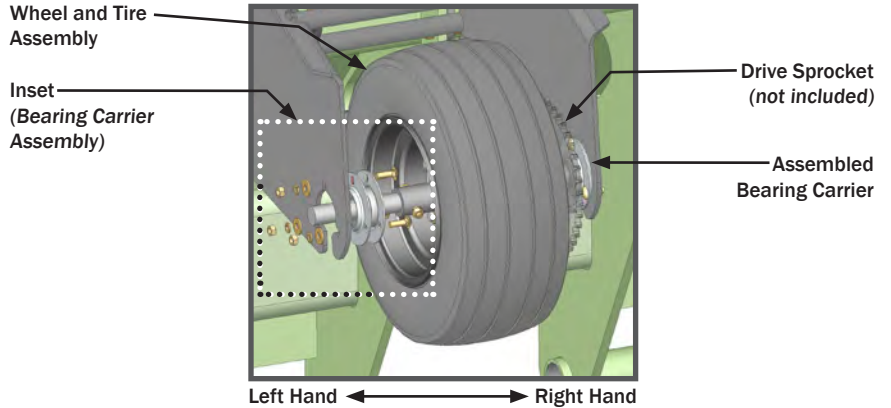

**BEARING CARRIER ASSEMBLY**

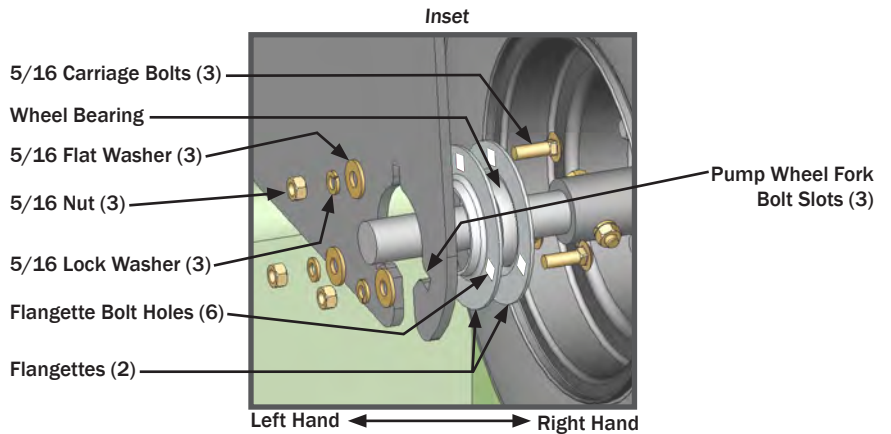

1. Align (3) flangette bolt holes.
2. “Snap” both flangettes around wheel bearing.
3. Align (3) flangette bolt holes and (3) pump wheel fork bolt slots.
4. Thread (3) carriage bolts through both flangettes and (3) pump wheel fork bolt slots.
5. Place (3) flat washers and (3) lock washers on each of the (3) carriage bolts.
6. Secure bearing carrier assembly to pump wheel fork with nuts.
7. Repeat procedure on right hand side of wheel and tire assembly.
8. Tighten all hardware to proper torque specifications. (pg. 64)



## PREPARATION AND SETUP

### INSTALLATION TIRE DRIVE FERTILIZER PUMP MOUNT

Tire Drive Fertilizer Pump Mount (fully assembled and installed)

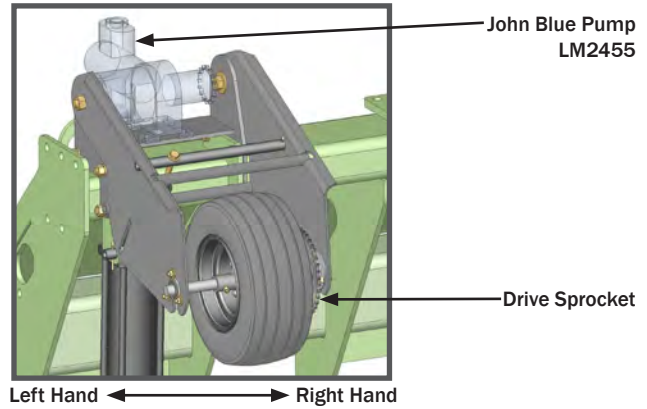

**NOTE:** The John Blue pump and drive sprocket are not included in the tire drive pump mount package when purchased from Orthman Mfg., Inc.

1. Fully extend the lift wheel cylinders.
2. Remove cylinder locks and return to storage position.
3. Insert a 2" cylinder stop on each lift wheel cylinder rod.
4. Lower Caddy to the field position. (as pictured below)

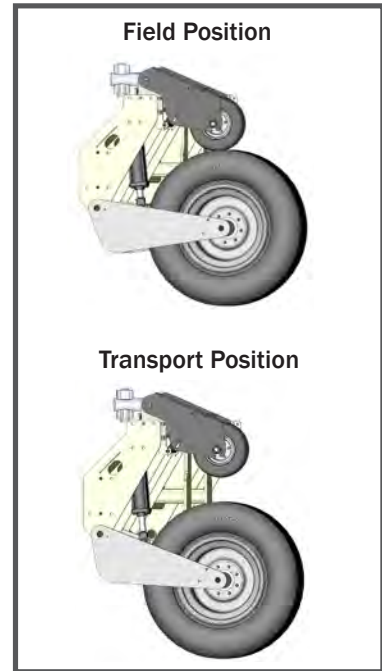
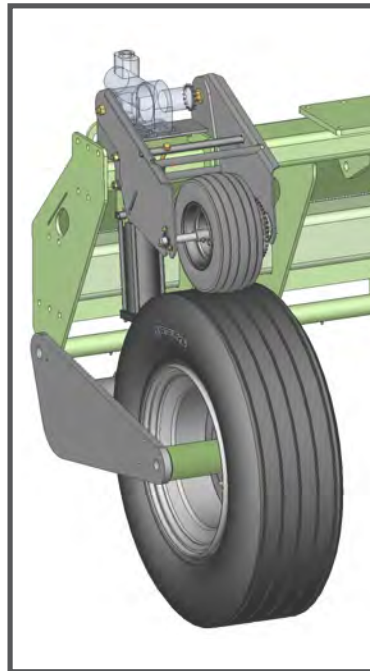



## PREPARATION AND SETUP

### LIFT WHEEL PACKAGE

The Caddy is available in four and six lift wheel configurations to carry a wide variety of implement sizes. A wide stance creates stability in the field as well as during transport. To increase carrying capacity, optional lift wheels (2) are available for addition to a four wheel Caddy. Additional lift wheels mount directly to the Caddy frame side plate.

Optional lift wheels (2) are mounted to both the right and left hand Caddy side plates. For the purposes of the following installation instructions, the left hand Caddy side plate is illustrated. The right hand lift wheel to Caddy side plate installation will mirror the following instructions and illustrations.

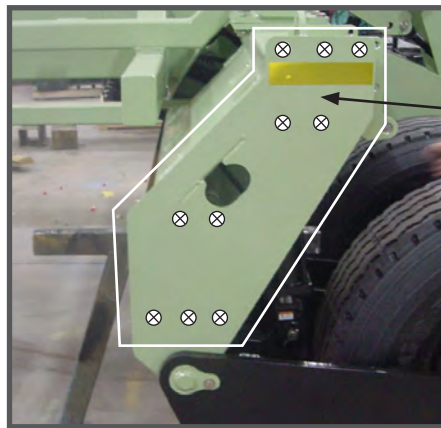

Left Hand Caddy Side Plate  
Lift Wheel Mounting Holes (10) ⊗

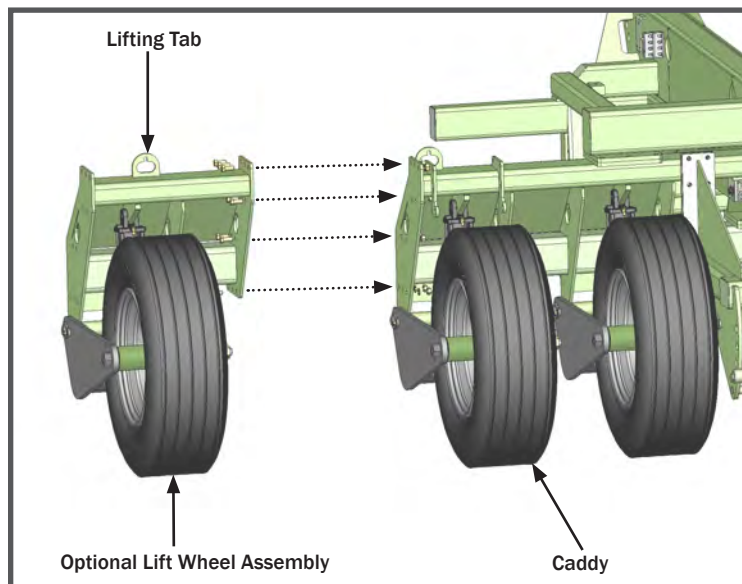





## PREPARATION AND SETUP

### INSTALLATION LIFT WHEEL PACKAGE



**AVOID CRUSHING.** Lower implement to the ground, place tractor in park, turn off engine, and remove key. Park implement on a clean, dry, and level surface. An uneven surface could cause implement to shift or fall, resulting in personal injury or death, as well as implement damage.

**USE BAR STANDS TO SUPPORT THE IMPLEMENT.** Securely support all implement components that must be raised. Remove any buildup of grease, oil, or debris prior to installing the lift wheel package.



153-167

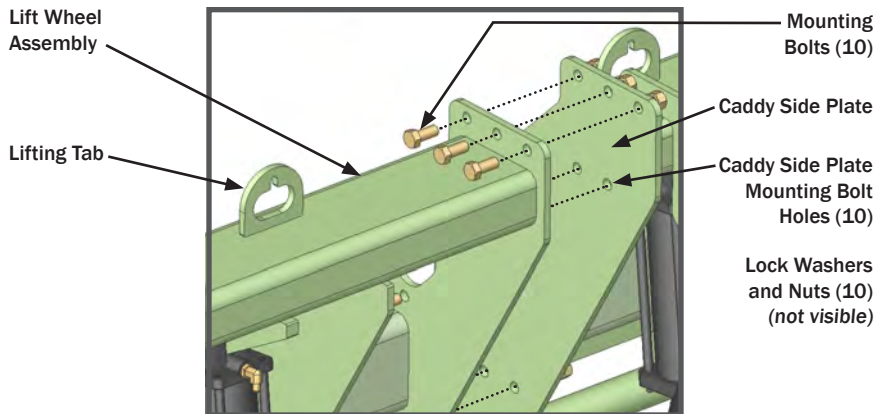
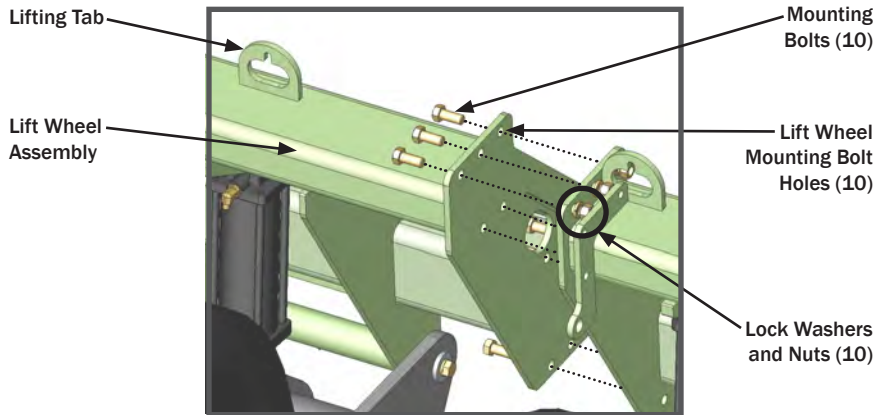

1. Utilize a lifting mechanism, (ie., cherry picker, crane, forklift, and the lift wheel lifting tab) to support lift wheel assembly weight.
2. Align lift wheel assembly and (10) Caddy side plate mounting bolt holes.
3. Insert (10) mounting bolts through (10) lift wheel mounting bolt holes and (10) Caddy side plate mounting bolt holes (10). (see note)
4. Use (10) lock washers and nuts to secure lift wheel assembly to Caddy side plate.
5. Tighten all hardware to proper torque specifications. (pg. 64)

**NOTE:** Hand tighten hardware until all 10 units of hardware are in place. Then proceed to tighten all hardware to the proper torque specifications.





## PREPARATION AND SETUP

### INSTALLATION LIFT WHEEL PACKAGE HYDRAULIC COMPONENTS



• **AVOID CRUSHING.** Lower implement to the ground, place tractor in park, turn off engine, and remove key. Park implement on a clean, dry, and level surface. An uneven surface could cause implement to shift or fall, resulting in personal injury or death, as well as implement damage.

• **USE BAR STANDS TO SUPPORT THE IMPLEMENT.** Securely support all implement components that must be raised. Remove any buildup of grease, oil, or debris prior to installing lift wheel package hydraulic components.



• Escaping pressurized hydraulic fluid can penetrate skin, resulting in injury or death. Relieve hydraulic system pressure before installing additional lift wheel hydraulic components. Wear protective gloves and safety glasses or goggles when working with hydraulic systems. If an accident occurs, see a doctor immediately for proper treatment.

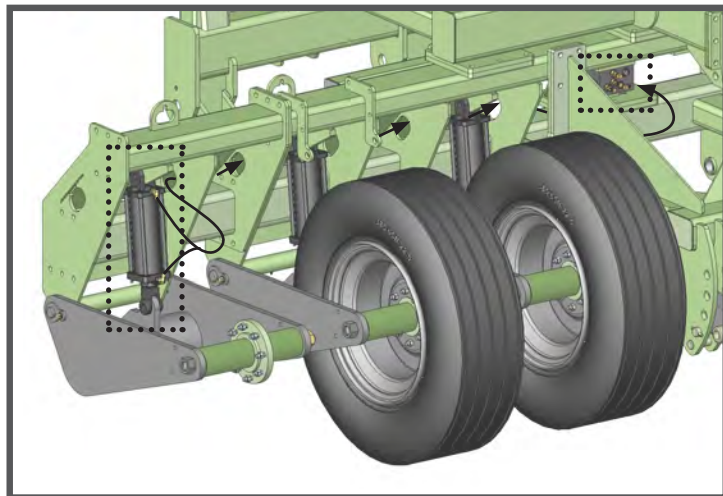

(lines and arrows indicate hydraulic hose routing)

Inset

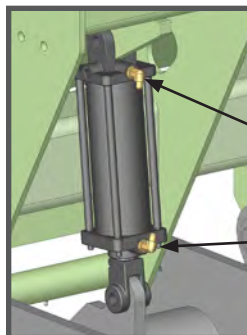

(left cylinder)

Inset

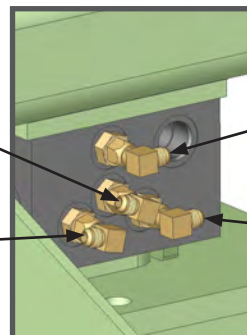

(rear hydraulic manifold)

(not pictured)

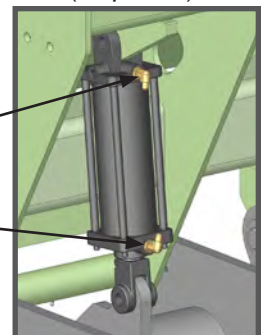

(right cylinder)



1. Route hydraulic hoses as illustrated above.
2. Attach hydraulic fittings to cylinders and manifold as illustrated above.
3. Tighten block fittings to 40 ft/lbs and hose ends to 15 ft/lbs.



## PREPARATION AND SETUP

### CADDY TO PRIMARY IMPLEMENT CONNECTION

**DANGER**

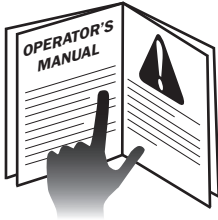

**USE EXTREME CAUTION WHEN CONNECTING CADDY TO PRIMARY IMPLEMENT.** Carefully read and understand the entire Caddy to primary implement connection section before attempting to accomplish any instructions illustrated in this section. It is imperative that the instructional processes are fully understood before proceeding.

Caddy to primary implement connection instructions require equipment not common to all agricultural operations. It is highly advisable for all personnel involved to thoroughly read and understand the entire manual before attempting to connect the Caddy to the primary implement.

#### PRIMARY THREE POINT HITCH

Lower Hitch Tug Pin Position

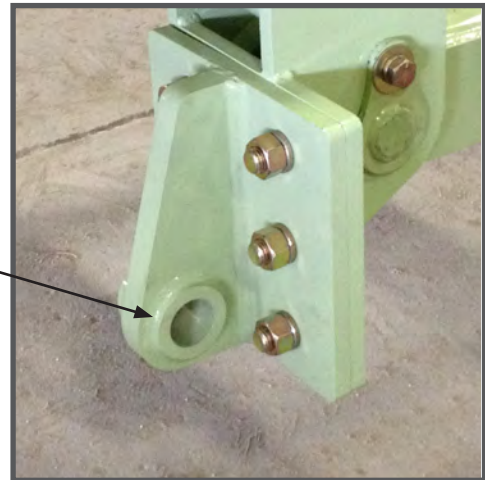

#### PRIMARY IMPLEMENT THREE POINT HITCH

Third Link Rear Pin Hole

Left Lower Hitch Tug Pin

Right Lower Hitch Tug Pin



(right side primary implement (1tRIPr) hitch)



## PREPARATION AND SETUP

### CADDY TO PRIMARY IMPLEMENT CONNECTION



- **AVOID CRUSHING.** Lower implement to the ground, place tractor in park, turn off engine, and remove key. Park implement on a clean, dry, and level surface. An uneven surface could cause implement to shift or fall, resulting in personal injury or death, as well as implement damage.
- **SUPPORT THE IMPLEMENT.** Use Caddy jack stand to support the implement. Remove any buildup of grease, oil, or debris prior to connecting the Caddy to primary implement.

Caddy to primary implement connection consists of “leapfrogging” the Caddy hitch over the primary implement.

(Optional dual fertilizer tanks, fertilizer pump mount, and additional lift wheels are removed to better illustrate the Caddy to primary implement connection processes.)

**NOTE:** Caddy to primary implement connection is simplified if the Caddy lift wheel cylinders utilize 2 inch cylinder stops. (pg. 23) Refer to (pg. 57) Caddy to tractor hydraulic connections. Connecting the red (Caddy to tractor) hydraulic connections will allow the lift wheels to lift the Caddy frame to insert a 2 inch cylinder stop per lift wheel cylinder. Lower the Caddy to the field (down) position before proceeding with the following instructions. All of the following illustrations are as if the 2 inch cylinder stops are in place.

1. Position the Caddy and primary implement and illustrated below.



153-167

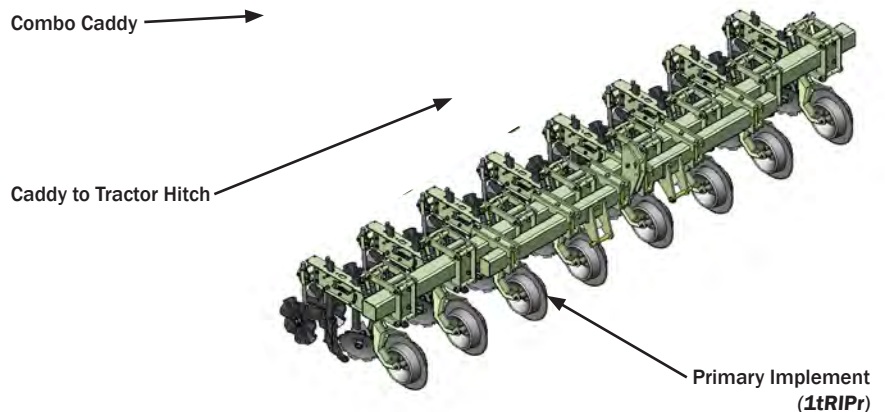



**PREPARATION AND SETUP**

**CADDY TO PRIMARY IMPLEMENT CONNECTION**



2. Distinguish desired primary three point hitch third link pin and lower hitch tug pin positions needed to match primary implement hitch.

**NOTE:** Typically a 1tRIPr is used as the primary implement. If a planter is used as the primary implement, refer to the bottom illustration on this page. All illustrations regarding Caddy to primary implement instructions utilize a 1tRIPr as the primary implement.

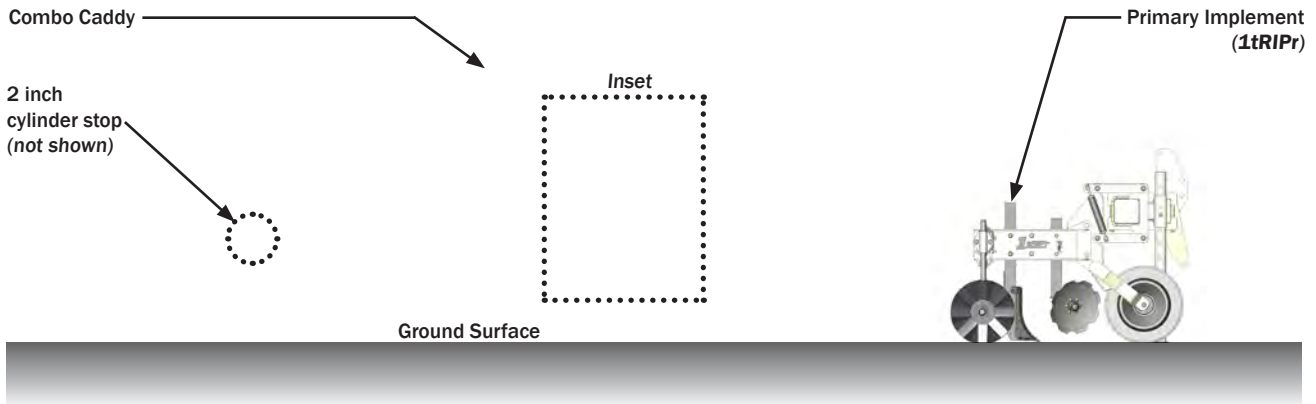

**\*1tRIPr pin positions:**



153-167

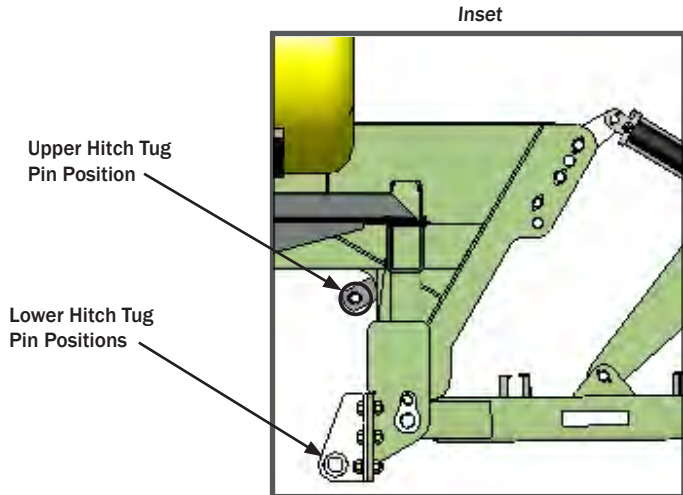



**PREPARATION AND SETUP**

**CADDY TO PRIMARY IMPLEMENT CONNECTION**



153-167

- Securely attach Caddy hitch to a lifting mechanism (*farmhand, forklift, crane, etc.*) capable of lifting the Caddy hitch up and over the highest point of the primary implement. Make sure Caddy hitch is securely attached to the lifting mechanism with multiple chains, straps, etc.

**CADDY HITCH**

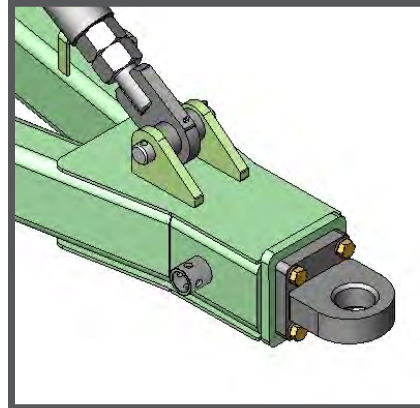

• **AVOID ROLLOVER.** Make sure the lifting mechanism is properly weighted and has a lifting capacity capable of lifting the Caddy hitch up and over the primary implement.

- Once the Caddy hitch and lifting mechanism are securely attached, slightly lift Caddy hitch with the lifting mechanism. (*Caddy will creep forward*)

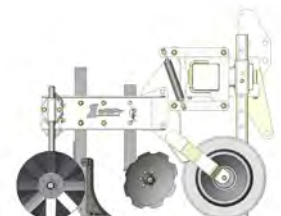

Ground Surface



**PREPARATION AND SETUP**

**CADDY TO PRIMARY IMPLEMENT CONNECTION**



- **AVOID CRUSHING.** Keep all personnel clear of all implements when Caddy is suspended above ground. Mechanical failure or loss of control of the lifting mechanism could cause implement to shift or fall, resulting in injury or death, as well as implement damage.

5. Once Caddy jack stand is in the storage position, continue to lift Caddy hitch upward. Have an assistant(s) view from the side(s) to confirm Caddy height will clear primary implement height.

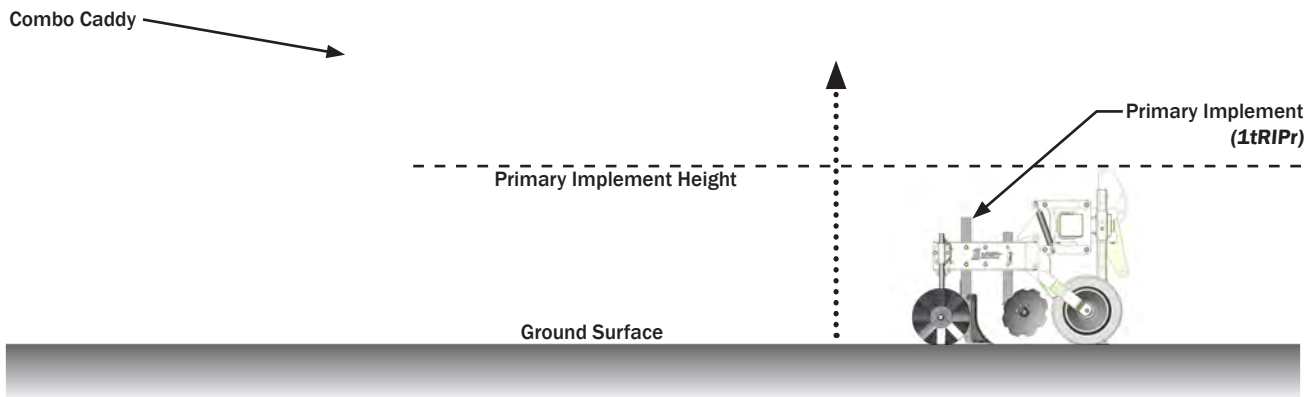

153-167

- **AVOID CRUSHING.** Keep all personnel clear of all implements when Caddy is suspended above ground. Mechanical failure or loss of control of the lifting mechanism could cause implement to shift or fall, resulting in injury or death, as well as implement damage.

6. Once Caddy height is confirmed to clear the primary implement height, begin to pull Caddy forward with the lifting mechanism. Continue to have an assistant(s) view from the side(s) to confirm Caddy height will clear primary implement height.

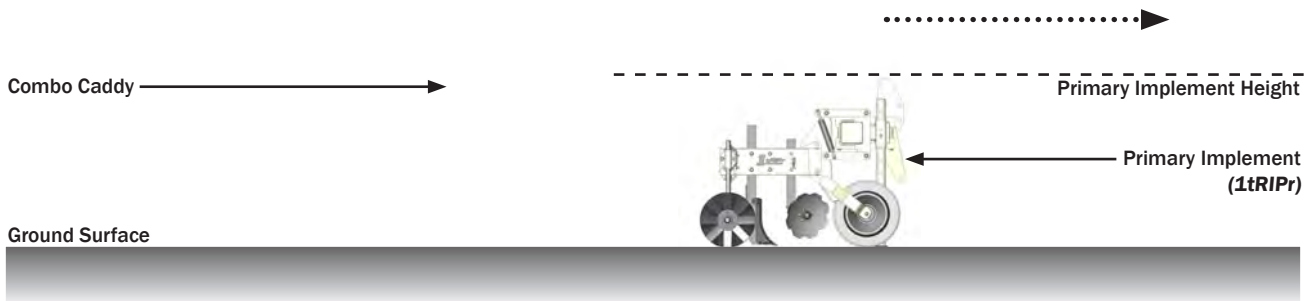



**PREPARATION AND SETUP**

**CADDY TO PRIMARY IMPLEMENT CONNECTION**



- **AVOID CRUSHING.** Keep all personnel clear of all implements when Caddy is suspended above ground. Mechanical failure or loss of control of the lifting mechanism could cause implement to shift or fall, resulting in injury or death, as well as implement damage.

7. Proceed to pull Caddy forward with the lifting mechanism until Caddy is positioned as illustrated below.

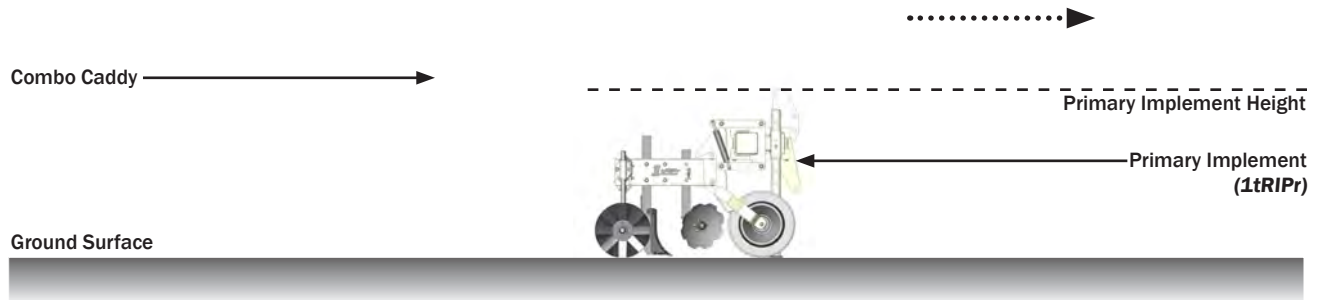

153-167

- **AVOID CRUSHING.** Keep all personnel clear of all implements when Caddy is suspended above ground. Mechanical failure or loss of control of the lifting mechanism could cause implement to shift or fall, resulting in injury or death as well as implement damage.

8. Begin to **SLOWLY** lower the Caddy to match illustration below. Continue to have an assistant(s) view the lowering process from a safe distance to make sure the implements do not interfere with each other. Once the Caddy is positioned as illustrated below, stop lowering the Caddy.

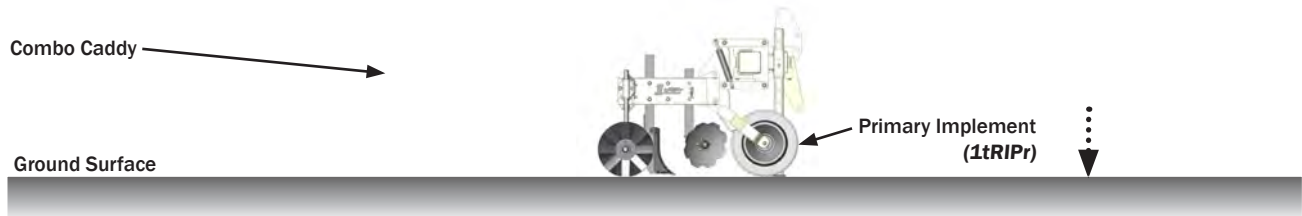

9. Return Caddy jack stand to original position. (refer to step 4)

**NOTE:** Caddy to primary implement connection is simplified if the Caddy lift wheel cylinders utilize 2 inch cylinder stops. Caddy frame height may need slight adjustment in order to achieve Caddy to primary implement connection. (pg. 57, red Caddy to tractor connections)





**PREPARATION AND SETUP**

**CADDY TO PRIMARY IMPLEMENT CONNECTION**



- **AVOID CRUSHING.** Keep all personnel clear of all implements when Caddy is suspended above ground. Mechanical failure or loss of control of the lifting mechanism could cause implement to shift or fall, resulting in injury or death, as well as implement damage.

**10.** Continue to **SLOWLY** lower the Caddy to the ground surface as illustrated below. Leave the Caddy hitch attached to the lifting mechanism in order to slightly maneuver the Caddy if needed.

- **AVOID CRUSHING.** Make sure three point Caddy bar stands or drawbar Caddy jack stand are set to original positions as illustrated below. Further Caddy to primary implement connection will require personnel to work underneath the Caddy frame. Three point Caddy bar stands or drawbar Caddy jack stand will serve as a safety precaution if the lifting mechanism should fail.

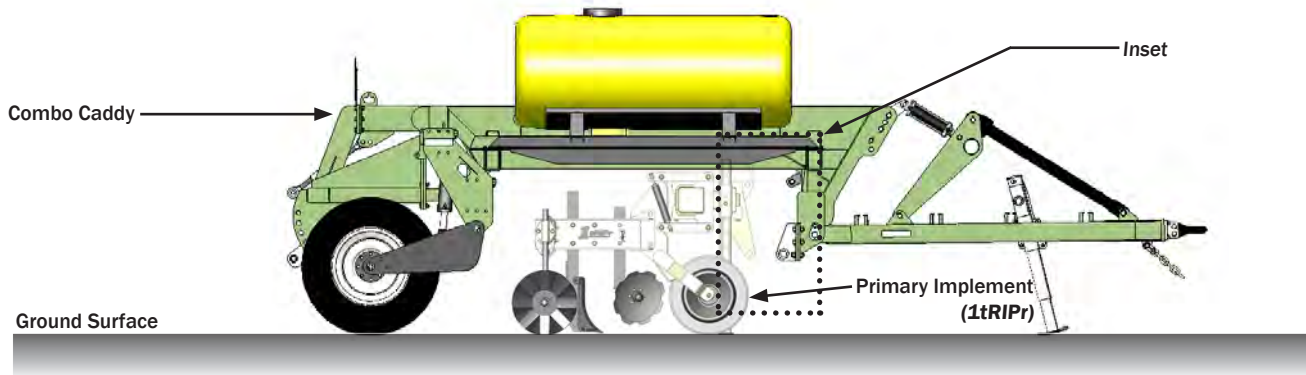

153-167

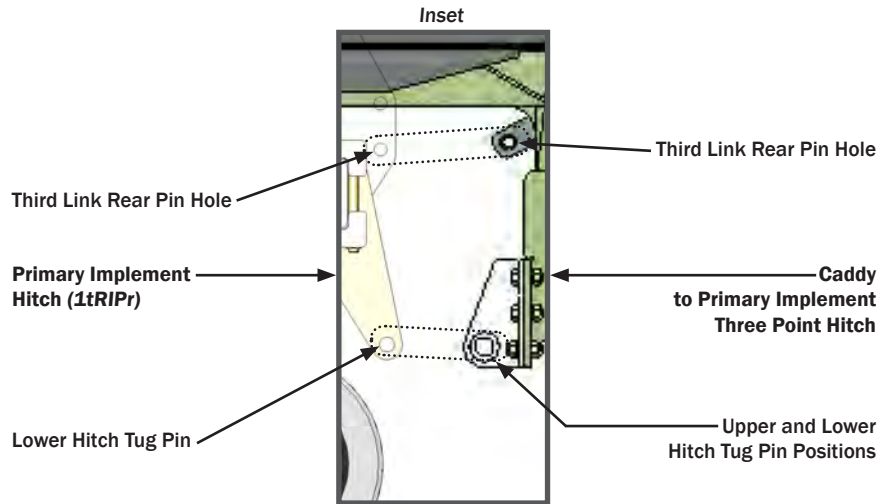

**11.** Attach Caddy to **1tRIPr** as illustrated above. Lower Caddy hitch to the ground to rest on bar stands or jack stand. Disconnect Caddy hitch from lifting mechanism.





## PREPARATION AND SETUP

### CADDY TO TRACTOR CONNECTION DRAWBAR CADDY



- **AVOID CRUSHING.** Do not stand between tractor and implement when connecting or disconnecting implement. Serious injury or death can result from being trapped between the tractor and implement.
- **USE DRAWBAR CADDY JACK STAND TO SUPPORT THE IMPLEMENT.** Securely support all implement components that must be raised.

#### CADDY HITCH

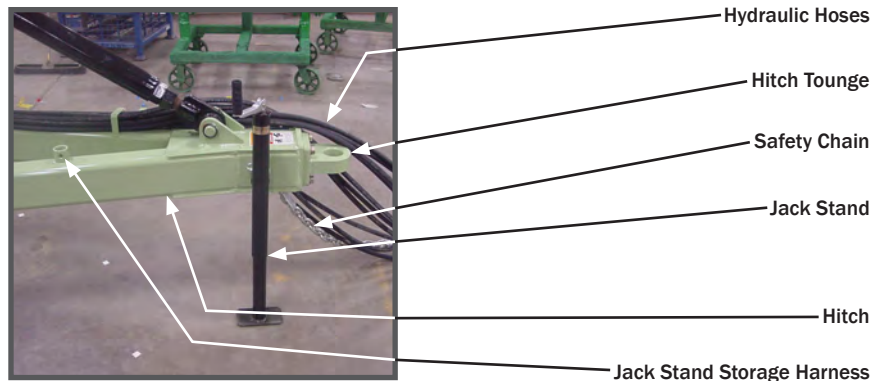

153-167

#### TRACTOR DRAWBAR

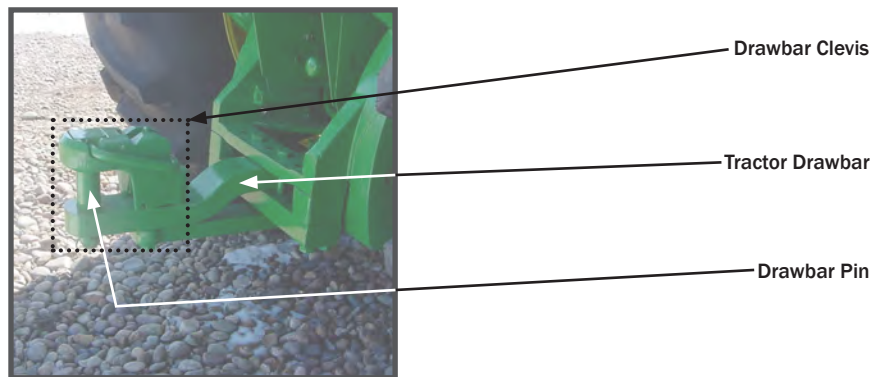

1. Remove drawbar pin.
2. Place hydraulic hoses and safety chain in order to not interfere.
3. Vertically adjust hitch tongue height to match tractor drawbar height.
4. Maneuver tractor until hitch tongue and clevis pin holes are aligned.
5. Replace drawbar pin.
6. Utilize safety chain in case of drawbar pin failure.
7. Raise jack stand and remove from harness.
8. Store jack stand on storage harness.
9. Connect hydraulic hoses according to operator preferences. (pg. 57)



## PREPARATION AND SETUP

### LIFT WHEEL TIRE SCRAPERS

Optional lift wheel tire scrapers are available to remove field residue from Caddy lift wheel tires. Excessive buildup of field residue will adversely affect both carried implements by essentially lifting the Caddy and in turn lifting the carried implements to an undesirable operating height.

When utilizing a tire drive fertilizer pump with the Caddy it is highly advisable to, at a minimum, install a lift wheel tire scraper on the pump drive Caddy tire. Installing lift wheel tire scrapers on all Caddy lift tires is advisable to maintain desired Caddy height at all times.

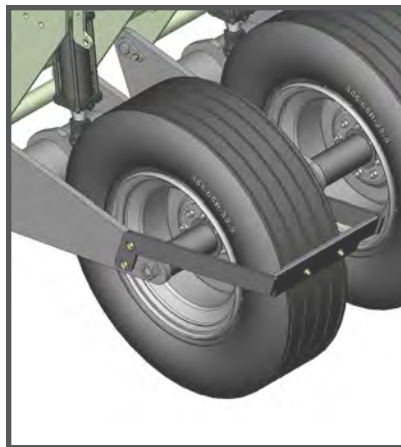

### INSTALLATION LIFT WHEEL TIRE SCRAPERS

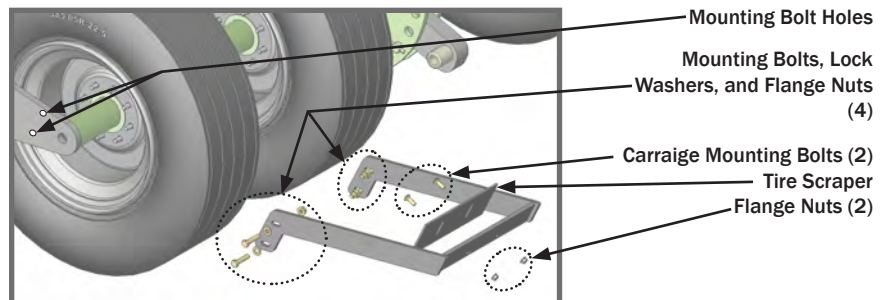

1. Mount tire scraper bracket to lift wheel with mounting bolts, lock washers, and flange nuts (4).
2. Mount tire scraper to scraper bracket with carriage mounting bolts and flange nuts (2).
3. Tighten all hardware to proper torque specifications. (pg. 64)

**NOTE:** When installing the tire scraper, do not allow tire scraper to come into contact with the tire. Tire to scraper contact will cause premature tire wear.



## PREPARATION AND SETUP

### **CADDY TO SECONDARY IMPLEMENT CONNECTION**

The Caddy is engineered to essentially carry two three point implements. A typical configuration would entail a **1tRIPr** carried by the primary three point hitch then followed by a planter carried by the secondary three point hitch.

Various operations utilize various types of equipment. Thus the information presented in this Caddy to secondary implement connection is designed to familiarize the operator with the secondary three point hitch and its capabilities. Operator preference and type of secondary implement will dictate pin positions.

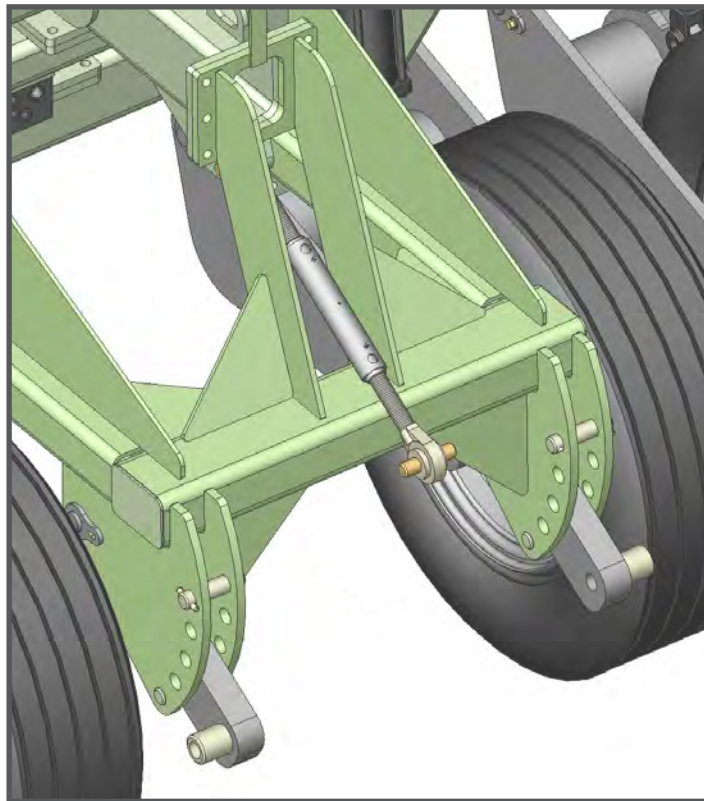

**NOTE:** Typically the lower hitch tugs are utilized in the position illustrated above when utilizing a planter as the secondary implement. Adjustment of lower hitch tugs may or may not be necessary.



## PREPARATION AND SETUP

### CADDY TO SECONDARY IMPLEMENT CONNECTION



**⚠️ AVOID CRUSHING.** Lower implement to the ground, place tractor in park, turn off engine, and remove key. Park implement on a clean, dry, and level surface. An uneven surface could cause implement to shift or fall, resulting in personal injury or death, as well as implement damage.

**• SUPPORT THE IMPLEMENT.** Use three point Caddy hitch bar stands or drawbar Caddy jack stand to support the implement. Remove any buildup of grease, oil, or debris prior to connecting Caddy to secondary implement.

### SECONDARY THREE POINT HITCH



153-167

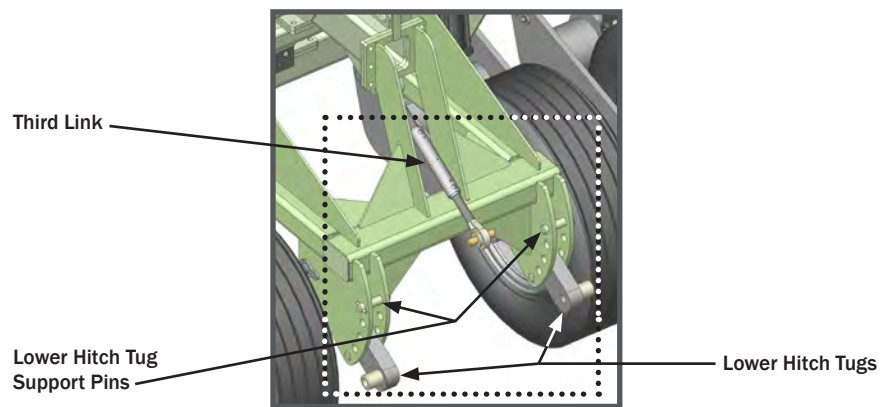

Inset

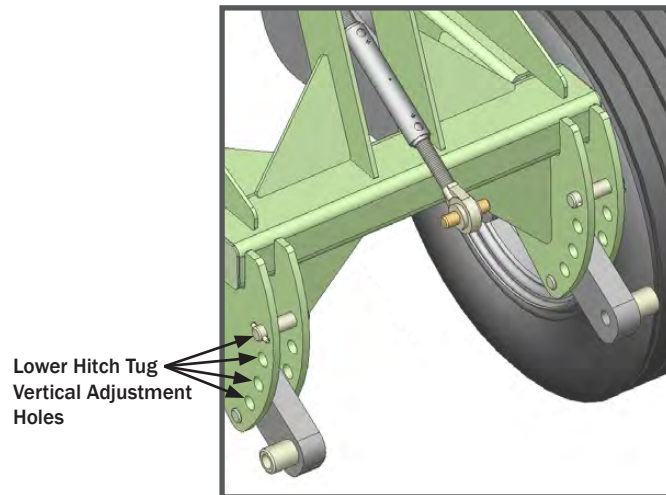

1. Utilize lower hitch tug support pins to achieve desired height of lower hitch tugs.
2. Manipulate height of lower hitch tugs and length of the third link to achieve Caddy to secondary implement connection.





**PREPARATION AND SETUP**

**SIMPLIFIED HYDRAULIC SCHEMATIC**

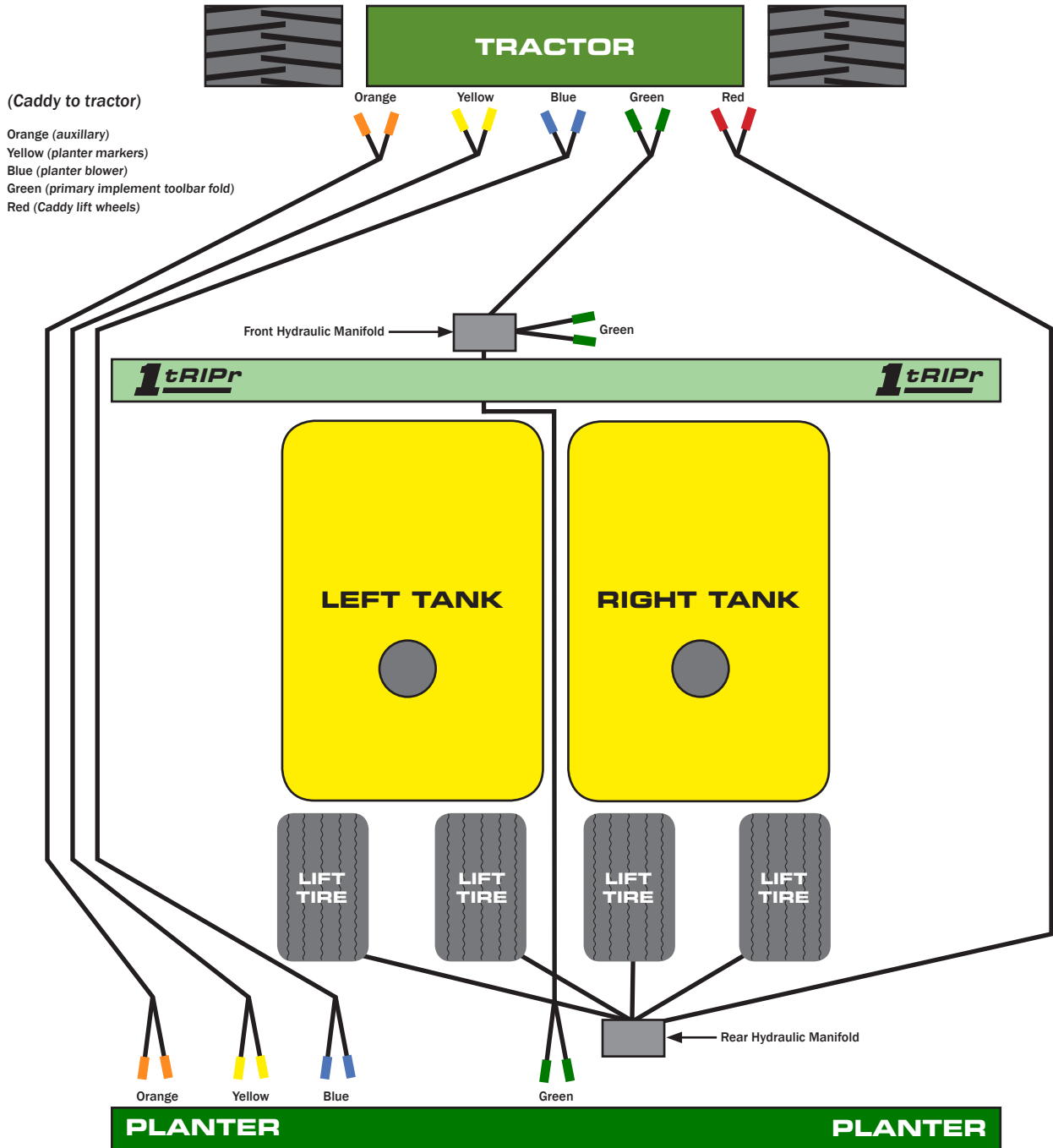

(Caddy to tractor)

- Orange (auxiliary)
- Yellow (planter markers)
- Blue (planter blower)
- Green (primary implement toolbar fold)
- Red (Caddy lift wheels)

(Caddy to secondary implement)

- Orange (auxiliary)
- Yellow (planter markers)
- Blue (planter blower)
- Green (secondary implement toolbar fold)



**FIELD SETTINGS**

**FIELD SETTINGS**

**CADDY HEIGHT**

The Caddy does not involve any ground engaging parts so field settings are limited. Caddy lift wheel cylinders determine the height of the Caddy frame when in the field position. The cylinder stop package allows for the adjustment of Caddy frame height. The primary and secondary implement operation heights are in direct proportion to the position of the Caddy lift wheel cylinders.

It is recommended to remain utilizing a 2 inch cylinder stop on each of the lift wheel cylinders for the initial field trial. After initial field trial, it may be necessary to add/remove cylinder stops to achieve desired primary and secondary implement settings. Desired toolbar heights and various field and application issues may require adjustment of lift wheel cylinder stops.

**NOTE:** The illustration below is as if 2 inch cylinder stops are in place. See inset.

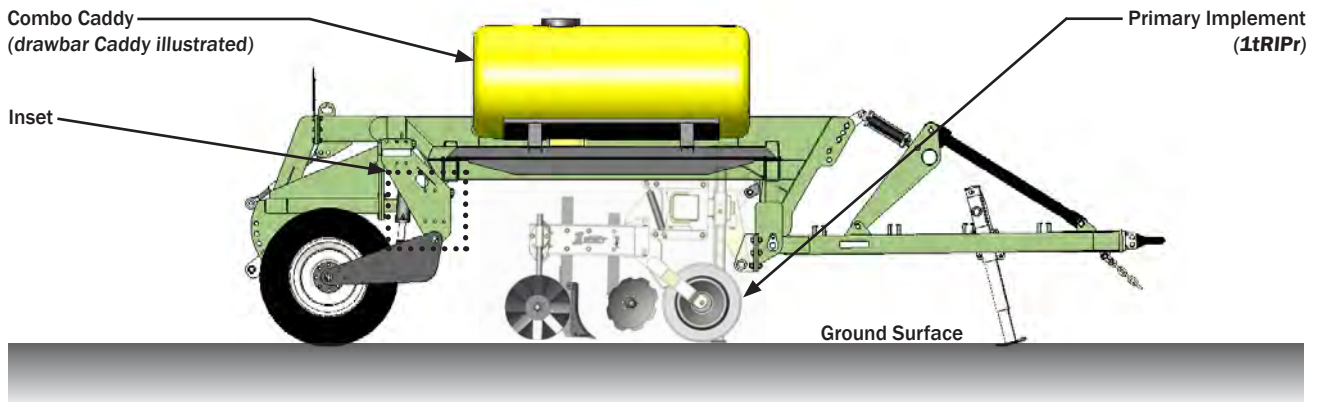

**NOTE:** When utilizing a 1tRIPr as the primary implement, read the 1tRIPr operator's manual and make sure row units are set to the shipping configuration for the initial field trial. The 1tRIPr is not designed to bear the weight of the Caddy. Too few cylinder stops can cause the 1tRIPr parallel linkage to bottom out and cause adverse 1tRIPr operation and wear.

Caddy height must be set properly to allow the primary and secondary implements to operate correctly. Although adjustment may be slight, it is imperative to achieve the proper Caddy height setting in order that the carried implements and the Caddy work efficiently.



**TROUBLESHOOTING**

**TROUBLESHOOTING**



• **AVOID CRUSHING.** Make sure all personnel are clear of the implement. Lower implement to the ground, place tractor in park, turn off engine, and remove key. Park implement on a clean, dry, and level surface. An uneven surface could cause implement to shift or fall, resulting in personal injury or death, as well as implement damage.

• **SUPPORT THE IMPLEMENT.** Use Caddy jack stand to support the implement. Remove any buildup of grease, oil, or debris prior to working on implement.



153-167

It is highly advisable for all personnel involved in the operation to thoroughly read and understand the entire content of this manual before attempting to operate or work on the Caddy.

**INSTALLING DUAL FERTILIZER TANKS:**

Refer to (pg. 27) for dual fertilizer tank installation and information. When installing dual fertilizer tanks, the gallon indicator can actually face toward or away (operator preference) from the tractor cab. When installing, slightly thread all hardware before tightening to torque specifications (pg. 64). Allowing slight play should allow all hardware to be utilized properly.



**INSTALLING OF TIRE DRIVE FERTILIZER PUMP MOUNT.**

Refer to (pg. 30) for tire drive fertilizer pump mount installation and information. The tire drive fertilizer pump mount does not include a pump or pump drive sprocket. Both of these items need to be provided by the producer.

Caddy pump drive tire: 48.5" circumference.

Caddy lift tire: 136.5" circumference.

Ground speed: operator preference.

The information provided above, in addition to pump specifications, will allow for the correct calculation of pump drive sprocket specifications needed to achieve desired fertilizer application rate. (contact your fertilizer provider)

Make sure Caddy lift wheel cylinders are slightly extended (red - Caddy to tractor connections) to provide more working area. (pg. 57) **Use cylinder locks in case of hydraulic failure.**

Make sure to use correct hardware sizes.

Make sure drilled holes on both pump drive tubes are in the correct positions. (pg. 31, 32)

Make sure that both bearing carrier flanges are mounted to the inside of the pump wheel fork. (pg. 36)

Make sure the fertilizer pump drive tire comes into contact with the Caddy lift tire when the Caddy lift wheel cylinders utilize a 2 inch cylinder stop. (pg. 38)



**INSTALLING LIFT WHEEL PACKAGE:**

Make sure Caddy is in the lowered position utilizing 2 inch cylinder stops. Make sure optional lift wheel cylinder is retracted. Use the lifting tab and lifting mechanism to allow for easier manipulation of optional lift wheel position. (pg. 39)

When installing, slightly thread hardware prior to tightening to torque specifications. (pg. 64)





## TROUBLESHOOTING

### TROUBLESHOOTING



- **AVOID CRUSHING.** Make sure all personnel are clear of the implement. Lower implement to the ground, place tractor in park, turn off engine, and remove key. Park implement on a clean, dry, and level surface. An uneven surface could cause implement to shift or fall, resulting in personal injury or death, as well as implement damage.
- **SUPPORT THE IMPLEMENT.** Use Caddy jack stand to support the implement. Remove any buildup of grease, oil, or debris prior to working on implement.



153-167

### INSTALLING OF LIFT WHEEL PACKAGE HYDRAULIC COMPONENTS:

Refer to (pg. 41) for lift wheel package hydraulic components installation and information.

Make sure hoses are routed correctly and hose ends are attached to the proper manifold ports and torqued to the proper specifications. (pg. 41)

Make sure, after installation of additional lift wheels, all lift wheels appear and operate identically.

### PRIMARY IMPLEMENT CONNECTION (CADDY TO 1tRIPr):

Refer to (pg. 42) for Caddy to primary implement connection instructions and illustrations.

Make sure to utilize correct third link and lower hitch tug pin positions. (pg. 42, 44)

Make sure to utilize correct primary implement third link rear pin hole. (pg. 42)

Make sure to have 2 inch lift wheel cylinder stops in place. Using a 2 inch cylinder stop should allow easier connection to the primary implement. (pg. 25)

Use the correct third link front pin position to match either 1tRIPr or planter configuration. (pg. 44)

Use pin position illustration (pg. 48) when utilizing the 1tRIPr as the primary implement.

### CADDY TO TRACTOR CONNECTION:

Refer to (pg. 49) for drawbar Caddy to tractor connection instruction and illustrations.

Make sure to use the provided safety chain in case of drawbar pin failure.





## TROUBLESHOOTING



- AVOID CRUSHING.** Make sure all personnel are clear of the implement. Lower implement to the ground, place tractor in park, turn off engine, and remove key. Park implement on a clean, dry, and level surface. An uneven surface could cause implement to shift or fall, resulting in personal injury or death, as well as implement damage.
- SUPPORT THE IMPLEMENT.** Use Caddy jack stand to support the implement. Remove any buildup of grease, oil, or debris prior to working on implement.



153-167

### INSTALLING LIFT WHEEL TIRE SCRAPERS:

Refer to (pg. 50) for lift wheel tire scraper information and installation instructions.

### SECONDARY IMPLEMENT CONNECTION (CADDY TO PLANTER):

Refer to (pg. 51,52) for Caddy to secondary implement connection information, illustrations, and installation instructions.

### HYDRAULIC SCHEMATIC:

Refer to (pg. 53) for a simplified hydraulic schematic encompassing the tractor, Caddy, primary implement (1tRIPr), and secondary implement (planter).

Contact your Orthman dealer for more detailed hydraulic system information.





**MAINTENANCE**

**MAINTENANCE**

**⚠ PRACTICE SAFE MAINTENANCE**

- Proper maintenance is your responsibility. Maintenance neglect and/or poor maintenance practices can result in injury or death. Always use the proper tools to maintain implement.



- **AVOID CRUSHING.** Make sure all personnel are clear of the implement. Lower implement to the ground, place tractor in park, turn off engine, and remove key.



- **SUPPORT THE IMPLEMENT.** Use Caddy jack stand to support the implement. Park implement on a clean, dry, and level surface. An uneven surface could cause implement to shift or fall, resulting in injury or death, as well as implement damage. Securely support all implement components that must be raised. Remove buildup of grease, oil, or debris prior to maintaining implement.



- **AVOID ENTANGLEMENT.** Never lubricate or service implement in motion. Keep away from power driven parts when in motion. Disengage power sources prior to maintaining implement. Injury or death can result from contact with power driven parts when in motion.



- **AVOID CRUSHING.** Do not stand between the tractor and implement when connecting or disconnecting implement. Injury or death can result from being trapped between the tractor and implement.



- Escaping pressurized hydraulic fluid can penetrate skin, resulting in injury or death. Relieve hydraulic system pressure before connecting or disconnecting tractor. Use cardboard or wood, **NOT BODY PARTS**, to check for suspected hydraulic leaks. Wear protective gloves and safety glasses or goggles when working with hydraulic systems. If an accident occurs, see a doctor immediately for proper treatment.



## MAINTENANCE

### **PRACTICE SAFE MAINTENANCE**



- Never operate a combustion engine in an enclosed area. Make sure there is adequate ventilation. Exhaust fumes can cause asphyxiation.



- Be extremely careful working around unshielded sharp edges. Injury may result from contact with sharp edges.
- Keep all parts in good condition and properly installed. Replace damaged or missing parts immediately.
- Remove tools and unused parts prior to implement operation.



### **LUBRICATION**

- Grease - use high quality multi-purpose grease. Follow recommended hourly service interval illustrated below.



**MAINTENANCE**

**LUBRICATION**



- Grease - use high quality multi-purpose grease.  
Follow recommended hourly service interval illustrated below.

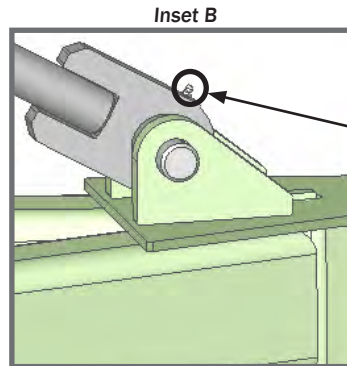



**MAINTENANCE**

**LUBRICATION**



- Grease - use high quality multi-purpose grease.  
Follow recommended hourly service interval illustrated below.

**DRAWBAR AND THREE POINT CADDIES**

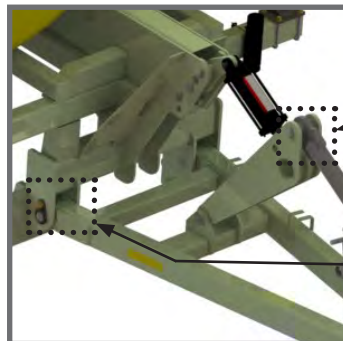

Inset A



Inset B

Inset A

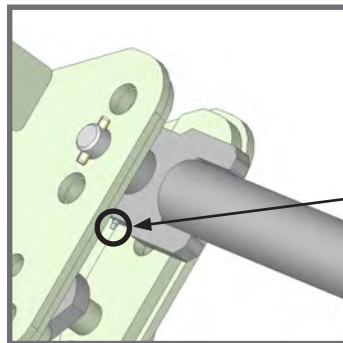

**GREASE**  
**100** ☒

Inset B

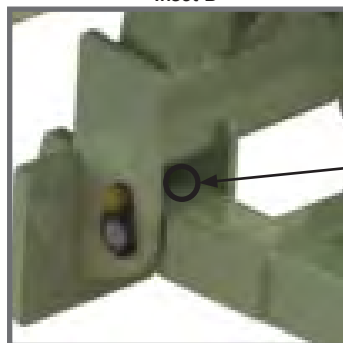

**GREASE**  
**50** ☒  
(1 per right and left side of Caddy)



**MAINTENANCE**

**LUBRICATION**



- Grease - use high quality multi-purpose grease.  
Follow recommended hourly service interval illustrated below.

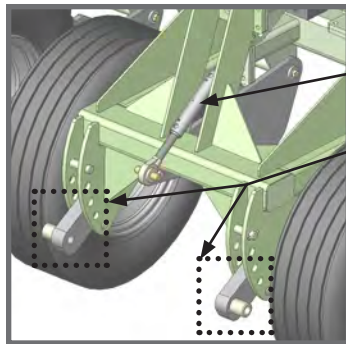

Third Link  
Lower Hitch Tugs



Lower Hitch Tug

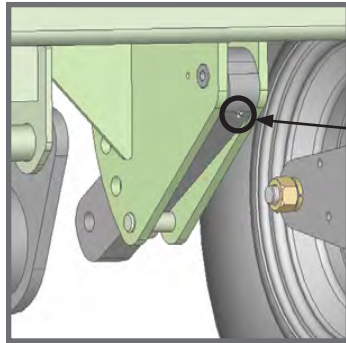

GREASE  
**50** ☒

(1 per right and left lower hitch tug)

Third Link

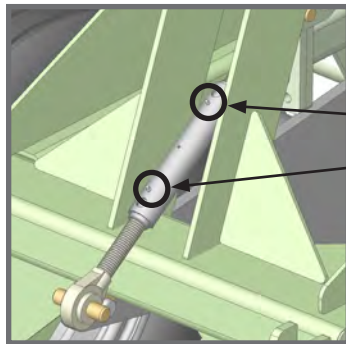

GREASE  
**100** ☒



**MAINTENANCE**

**LUBRICATION**



- Grease - use high quality multi-purpose grease. Follow recommended hourly service interval illustrated below.

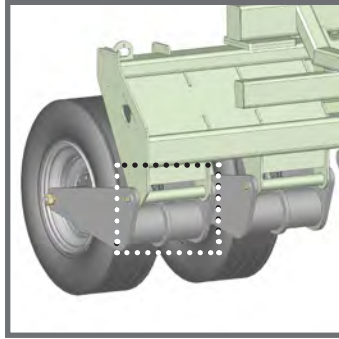

*Inset*

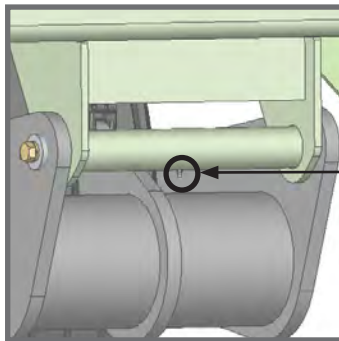

**GREASE**  
**10** ☒  
(1 per lift wheel)



**IMPLEMENT INSPECTION**



- When replacement parts are necessary for periodic maintenance and servicing, genuine factory replacement parts must be used to restore implement to original specifications. Replace broken or worn parts immediately. Contact your Orthman dealer for replacement parts.
- During break-in (40 hours), check hardware for proper torque every 10 to 20 hours. (pg. 64)
- Before each use, check hardware for wear and proper torque. (pg. 64) Replace damaged or missing hardware with hardware of identical grade to restore implement to original specifications.
- Do not allow debris to buildup on any surface of the implement.
- Replace all shields and guards. Be sure all tools, parts, and service equipment are removed prior to transporting equipment.



**MAINTENANCE****TORQUE SPECIFICATIONS****RECOMMENDED DRY BOLT TORQUE****SAE GRADE 5**

| <b>Bolt Size</b> | <b>ft. - lb.</b> |
|------------------|------------------|
| 3/8              | 32               |
| 7/16             | 52               |
| 1/2              | 80               |
| 9/16             | 115              |
| 5/8              | 160              |
| 3/4              | 280              |
| 7/8              | 455              |
| 1                | 680              |
| 1 1/8            | 850              |
| 1 1/4            | 1200             |

**SAE GRADE 8**

| <b>Bolt Size</b> | <b>ft. - lb.</b> |
|------------------|------------------|
| 3/8              | 36               |
| 7/16             | 59               |
| 1/2              | 88               |
| 9/16             | 130              |
| 5/8              | 175              |
| 3/4              | 315              |
| 7/8              | 510              |
| 1                | 760              |
| 1 1/8            | 1075             |
| 1 1/4            | 1500             |



**MAINTENANCE**

**⚠ IMPLEMENT STORAGE**

- Clean and touch up paint seasonally to avoid corrosion and rust. Contact your Orthman dealer for touch up paint.
- Inspect all decals and replace if missing or damaged. Contact your Orthman dealer for replacement decals. (pg. 15)
- Grease all zerks regardless of hourly interval prior to storage. (pg. 59)
- Check all hardware according to torque specifications prior to storage. (pg. 64)
- Replace worn or damaged parts prior to storage.
- Store inside if possible. Storing implement inside will prolong the life of Caddy components.
- **AVOID CRUSHING.** Make sure all personnel are clear of the implement. Lower implement to the ground, place tractor in park, turn off engine, and remove key.
- Storing the Caddy in the lowered position will relieve the lift cylinders of hydraulic pressure. Hydraulic systems tend to settle, endangering anything underneath the implement.
- **SUPPORT THE IMPLEMENT.** Use Caddy jack stand to support the implement. Store implement on a clean, dry, and level surface. An uneven surface could cause implement to shift or fall, resulting in personal injury or death, as well as implement damage. Securely support all implement components that must be raised. Store implement away from human activity.





**NOTES**

Large empty rectangular area for taking notes.



**NOTES**

A large, empty rectangular area intended for handwritten notes, framed by a thin black border.



**NOTES**

A large, empty rectangular area intended for handwritten notes, framed by a thin black border.